

TOWMOTOR®



T15LE

TPDL15E

TPD15E

TPD18E

TPD20(L)ER

TSD12EM

TSD12SM

TOD3E

TTD30E, TTD60E

PEDESTRIAN ELECTRIC HAND PALLET TRUCKS

PEDESTRIAN ELECTRIC HAND PALLET TRUCKS

PEDESTRIAN ELECTRIC PALLET TRUCKS

PEDESTRIAN POWERED PALLET TRUCKS

PLATFORM POWERED PALLET TRUCKS

PEDESTRIAN MONO MAST STACKERS

PEDESTRIAN TELESCOPIC MAST STACKERS

MINI ORDER PICKER

ELECTRIC TOW TRUCK



PEDESTRIAN ELECTRIC HAND PALLET TRUCKS PAGES 4 TO 13



PEDESTRIAN & PLATFORM ELECTRIC PALLET TRUCKS PAGES 14 TO 17



COMPACT PEDESTRIAN STACKERS PAGES 18 TO 19



MINI ORDER PICKER PAGES 20 TO 21



ELECTRIC TOW TRUCK PAGES 22 TO 23



AN ORIGINAL

Lester Sears founded Towmotor® Corporation in Cleveland, Ohio in 1919. It was a time when most things relied on brute manpower, especially when it came to the loading and unloading of goods. Like its name suggests, a Towmotor was a type of industrial tractor that pulled and pushed carts in, out and around warehouses and factories, which greatly increased productivity.

THE FIRST FORKLIFT

In 1933, Towmotor unveiled the world's first forklift—a vehicle that used front forks to lift and carry cargo while the back of the vehicle was counterbalanced to stabilise the load. What once took hours and thirty men to do, a Towmotor forklift did with just one driver and in a fraction of the time. Towmotor's "One man gangs," as they were often called, were so popular that all forklifts at the time were generally referred to as "Towmotors."

TOWMOTOR TODAY

Things have come a long way since our first "One man gang." Today, Towmotor continues building exceptional forklifts that are tough, reliable and represent exceptional value. But that's not all. We are committed to our customers. That's why Towmotor is backed by one of the industry's best after sales and service teams. Talk to a Towmotor representative today to see how we can help improve the way you handle your materials.

CONTENTS	PAGE
T15LE PEDESTRIAN ELECTRIC HAND PALLET TRUCK, 1.5T	4
TPDL15E PEDESTRIAN ELECTRIC HAND PALLET TRUCK, 1.5T	6
TPD15E PEDESTRIAN ELECTRIC PALLET TRUCK, 1.5T	10
TPD18E PEDESTRIAN ELECTRIC PALLET TRUCK, 1.8T	12
TPD20(L)ER PLATFORM ELECTRIC PALLET TRUCK, 2.0T	14
TSD12EM COMPACT PEDESTRIAN STACKERS, 1.2T, 1.6M - 1.95M	16
TSD12SM COMPACT PEDESTRIAN STACKERS, 1.2T, 1.6M - 2.5M - 3.0M	18
TOD3E MINI ORDER PICKER	20
TTD30E, TTD60E ELECTRIC TOW TRUCK	22



PEDESTRIAN ELECTRIC HAND PALLET TRUCK, 24V LI-ION

T15LE

1.5 tonnes

Li-ion
STANDARD

HIGH PERFORMANCE IN AN AFFORDABLE PACKAGE



Our affordable T15LE electric hand pallet truck provides the performance of a conventional powered pallet truck in a durable package. It's the perfect upgrade from a traditional hand pallet truck, removing the effort of pushing and pulling. Combining efficiency with productivity, it will provide many years of service.

The T15LE is ideally suited to light material handling applications - particularly those found in retail - for example in small supermarkets, pharmacies, health care centres and many others.

The motor and drive wheel have been coupled with a robust and proven manual hand pallet frame design. It is built to last, is comfortable to use and also offers practicality. The **lithium-ion battery** can be easily exchanged but also allows operators to 'opportunity charge'. This gives the added convenience of being able to charge anytime, anywhere without removing the battery.

KEY FEATURES

- 1,500 kg load capacity
- Comfortable handle with easy-to-reach controls
- Key switch and emergency stop button
- Robust, tried and tested hand pallet truck frame design
- Can be specified with single or double fork wheels
- Powered by 24V, 20Ah Li-ion battery
- Battery can be charged externally from the truck or in situ
- Horizontally mounted motor allows for easier maintenance



PEDESTRIAN ELECTRIC HAND PALLET TRUCK, 24V LI-ION T15LE 1.5 tonnes

CHARACTERISTICS			Towmotor	Towmotor	Towmotor	Towmotor	Towmotor	Towmotor	Towmotor
1.1	Manufacturer (abbreviation)		T15LEWPTP	T15LEIPTP	T15LEMPTP	T15LEHPTP	T15LEKPTP	T15LEJPTP	T15LEMPSP
1.2	Manufacturer's model designation		550 X 1000	685 X 1000	550 X 1150	685 X 1150	550 X 1220	685 X 1220	550 X 1150
1.3	Power source: (battery, diesel, LP gas, petrol)		Battery	Battery	Battery	Battery	Battery	Battery	Battery
1.4	Operator type: pedestrian, operator standing, operator seated		Pedestrian	Pedestrian	Pedestrian	Pedestrian	Pedestrian	Pedestrian	Pedestrian
1.5	Load capacity	Q (kg)	1500	1500	1500	1500	1500	1500	1500
1.6	Load center distance	c (mm)	600	600	600	600	600	600	600
1.8	Load wheels axle to fork face (forks lowered)	x (mm)	801	801	951	951	1021	1021	951
1.9	Wheelbase	Y (mm)	1086	1086	1236	1236	1306	1306	1236
WEIGHT									
2.1	Truck weight with load, with maximum battery weight	kg	109	111	111	113	112	114	110
2.2	Axle load with nominal load & maximum battery weight, drive load/side	kg	405/1024	406/1205	407/1204	408/1205	408/1204	410/1204	407/1203
2.3	Axle load without nominal load & with maximum battery weight, drive load/side	kg	80/29	81/30	82/29	83/30	83/29	85/29	82/28
WHEELS, DRIVE TRAIN									
3.1	Tyres: PT=Power Thane, Vul=Vulkollan, P=Polyurethane, N=Nylon, R=Rubber drive/load side		P	P	P	P	P	P	P
3.2	Tyre dimensions, drive side	(mm)	210	210	210	210	210	210	210
3.3	Tyre dimensions, load side	(mm)	80	80	80	80	80	80	80
3.5	Number of wheels, load/drive side (x=driven)		1x+2/4	1x+2/4	1x+2/4	1x+2/4	1x+2/4	1x+2/4	1x+2/2
DIMENSIONS									
4.4	Lift height	h_3 (mm)	110	110	110	110	110	110	110
4.5	Fork height, fully lowered	h_{13} (mm)	80	80	80	80	80	80	80
4.9	Height of tiller arm / steering console (min./max.)	h_{14} (mm)	635/1200	635/1200	635/1200	635/1200	635/1200	635/1200	635/1200
4.19	Overall length	l_1 (mm)	1430	1430	1580	1580	1650	1650	1580
4.20	Length to fork face	l_2 (mm)	430	430	430	430	430	430	430
4.21	Overall width	b_1 (mm)	550	685	550	685	550	685	550
4.22	Fork dimensions (thickness, width, length)	s/e/l (mm)	53/160/1000	53/160/1000	53/160/1150	53/160/1150	53/160/1220	53/160/1220	53/160/1150
4.25	Overall width of forks	b_5 (mm)	550	685	550	685	550	685	550
4.32	Ground clearance at center of wheelbase, (forks lowered)	m_2 (mm)	27	27	27	27	27	27	27
4.33	Working aisle width (Ast) with 1000 x1200 mm pallets, load crosswise, platform up/down	A_{st} (mm)	2062	2062	2180	2180	2250	2250	2180
4.34	Working aisle width (Ast) with 800 x1200 mm pallets, load lengthwise, platform up/down	A_{st} (mm)	1995	1995	2050	2050	2085	2085	2050
4.35	Turning radius	W_n (mm)	1230	1230	1380	13880	1450	1450	1380
PERFORMANCE									
5.1	Travel speed, with/without load	km/h	4.3/4.5	4.3/4.5	4.3/4.5	4.3/4.5	4.3/4.5	4.3/4.5	4.3/4.5
5.2	Lifting speed, with/without load	m/s	16/20	16/20	16/20	16/20	16/20	16/20	16/20
5.3	Lowering speed, with/without load	m/s	Manual	Manual	Manual	Manual	Manual	Manual	Manual
5.8	Gradeability, with/without load	%	5/20	5/20	5/20	5/20	5/20	5/20	5/20
5.10	Service brake		Electric	Electric	Electric	Electric	Electric	Electric	Electric
ELECTRIC MOTORS									
6.1	Drive motor capacity (60 min. short duty)	kW	0.75	0.75	0.75	0.75	0.75	0.75	0.75
6.2	Lift motor output at 15% duty factor	kW	0.5	0.5	0.5	0.5	0.5	0.5	0.5
6.4	Battery voltage/capacity at 5-hour discharge	V/Ah	24/20	24/20	24/20	24/20	24/20	24/20	24/20
6.5	Battery weight	kg	5.5	5.5	5.5	5.5	5.5	5.5	5.5
MISCELLANEOUS									
8.4	Level of noise at the ear level of the driver according to EN 12053	dB(A)	70	70	70	70	70	70	70

Continuing improvement may lead to changes in these specifications

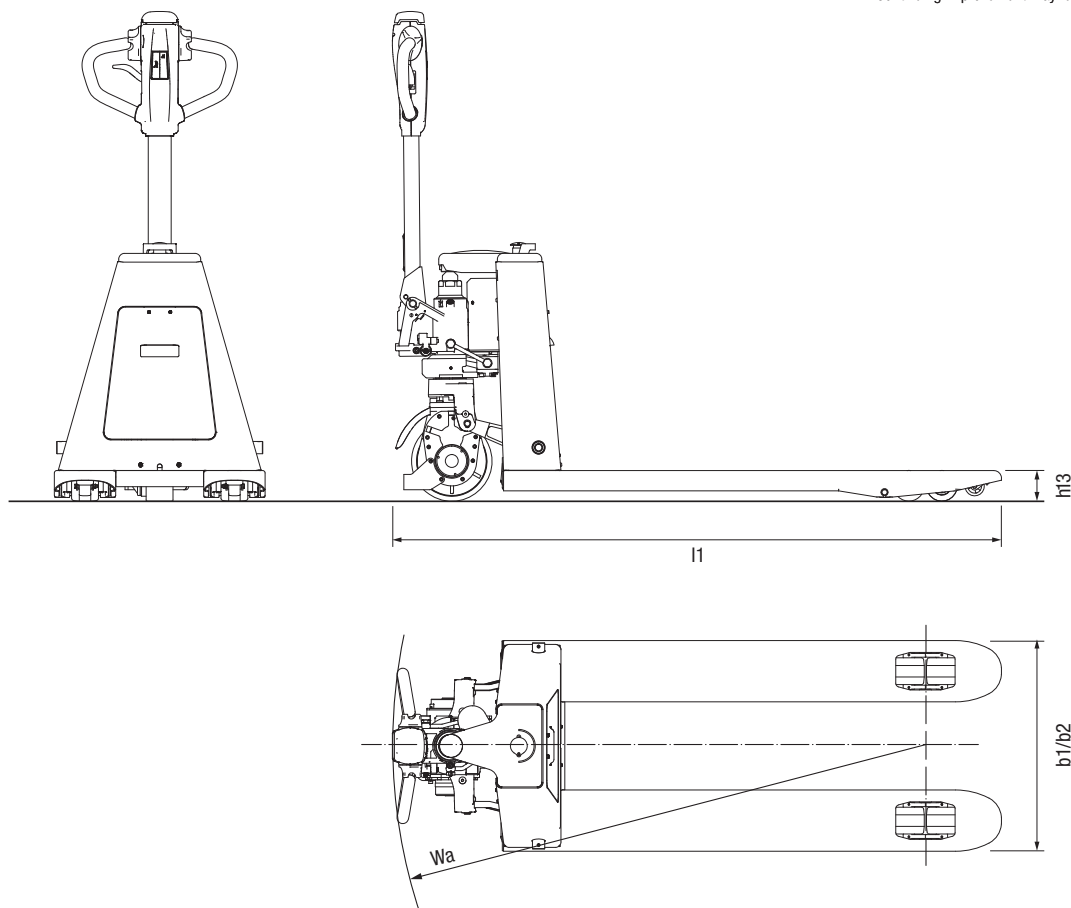

PEDESTRIAN ELECTRIC HAND PALLET TRUCK, 48V LI-ION

Li-ion
STANDARD

TPDL15E

1.5 tonnes

SIMPLE YET EFFECTIVE... A GREAT ALL-ROUNDER



Our TPDL electric pedestrian pallet trucks make moving products efficient and convenient.

They feature a 48-volt Lithium-Ion power source, which helps make them the perfect choice for short- and mid-distance runs.

The TPDL combines smart engineering with versatility making it the multi-use and user-friendly solution for nearly any application.

With its compact design, low service weight and small turning radius, the TPDL series is ideal for use in confined spaces, including: retail stores, trailers, containers and small warehouses.

The TPDL series of 1.5 tonne electric pedestrian pallet trucks feature electrical driving and lifting functions, as well as a manual lowering.

The exchangeable, maintenance-free, high-capacity **48V Lithium-Ion battery** provides up to six hours of productive use. The truck is supplied with an external charging dock - allowing you to charge an extra battery in just 3 hours, while the truck is still in use.

FRAME AND BODY

- **High quality, stable construction** gives a stable and durable platform.
- **Compact, lightweight, high-performing body design** provides exceptional maneuverability in tight areas.
- **Integrated rocker arm** is cast in one piece from solid steel to ensure maximum strength and reliability.

DRIVE

- **Maintenance free brushless (AC) wheel hub motor** with no wearable components like carbon brushes or contactors to replace over time offer long-lasting operation and low maintenance.
- **Patented low noise gearless hub motor design** allows tight integration into wheel hubs, thus eliminating the need for gears.

FORKS

- **Tapered fork tips and tandem PU rollers with fork tip rollers** for easy pallet entry and exit.
- **Reinforced chassis and forks with tapered ends** offers easy pallet entry.

BRAKES

- **Regenerative Brake System, incorporated into motor assembly, with electromagnetic (parking) brake**, improves the braking performance and working life of the electromagnetic brake.
- **Parking brake** automatically stops on gradients and ramps.
- **Kinetic energy from the regenerative brake system** charges the battery.

ELECTRICAL AND CONTROL SYSTEMS

- **48V/20Ah high capacity Lithium-Ion battery** lasts longer and is more powerful.
- **Li-Ion battery with no leaking hazardous battery gases and acids** does not require watering and provides maintenance-free operation.
- **External charger** makes it possible to charge the battery onboard.
- **External charging** allows charging of an extra battery while using the truck with only 3 hours charging time.
- **Battery interchangeability** means that batteries can be used across all TPDL models - regardless of capacity.

OPERATOR ENVIRONMENT AND CONTROLS

- **Ergonomic spring-loaded steering handle** with comfort grip for reduced operator fatigue.
- **Long tiller with large ergonomic handgrip** provides a comfortable hold and strain-free operation.
- **BDI, Battery charge-Discharge Indicator with hour meter** keeps operator informed of status.
- **Side castors** give improved stability.

OTHER FEATURES

- **Easy maintenance with no expensive handheld required**, only a laptop, software and a cable.
- **Polyurethane wheels and rollers** for smooth and quiet running and additional grip.
- **1.5 tonne capacity** ensures the TPDL Series suits a wide range of applications.

KEY FEATURES

- # 1 Compact design
- # 2 Quick-charging battery
- # 3 High-productivity tiller
- # 4 Maintenance-free battery
- # 5 Easy-entry forks
- # 6 Dual disc brake and motor integrated into traction wheel
- # 7 Universal battery exchange
- # 8 Digital battery discharge + hour meter

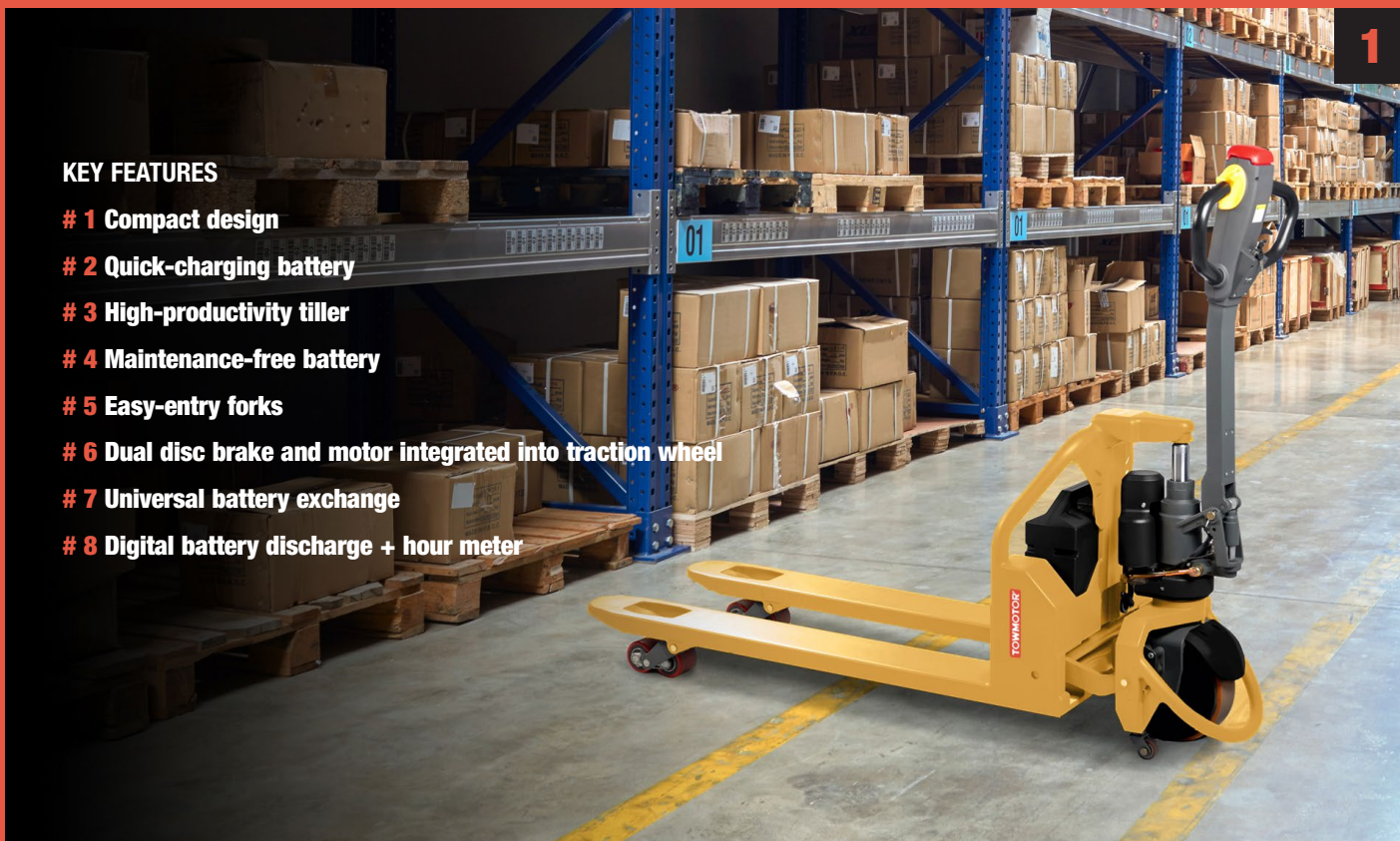

2

The TPDL's 48V lithium ion power source charges in just 3 hours and offers up to 6 hours of use, or 3 hours (approximately) when used continuously.



3

Turtle / Creep mode switch, for safe and easy maneuverability with the tiller-arm in upright position.
Reminder: The ergonomic handle allows full command of the truck's functionality, with the operator's hands in a natural vertical position. With the tiller arm in fully upright, the truck can be operated in the most restricted space for maximum manoeuvrability.



4

TPDL's 48V/20Ah high-capacity Li battery requires no watering and is easy to remove and exchange for fast changeovers.



5

Reinforced fork structure with tapered ends for easy pallet entry.



6

The disc brake and motor are integrated in the drive wheel for better protection.

PEDESTRIAN ELECTRIC HAND PALLET TRUCK, 48V LI-ION **TPDL15E** 1.5 tonnes

VDI - PERFORMANCE & DIMENSIONS

CHARACTERISTICS		Towmotor	Towmotor	Towmotor	Towmotor
		TPDL15EWPTP	TPDL15EIPTP	TPDL15EMPTP	TPDL15EMPSP
1.1	Manufacturer (abbreviation)	550 X 1000	680 X 1000	550 X 1150	550 X 1150
1.2	Manufacturer's model designation	Battery	Battery	Battery	Battery
1.3	Power source: (battery, diesel, LP gas, petrol)	Pedestrian	Pedestrian	Pedestrian	Pedestrian
1.4	Operator type: pedestrian, operator standing, operator seated	1500	1500	1500	1500
1.5	Load capacity	Q (kg)	600	600	600
1.6	Load center distance	c (mm)	802	802	952
1.8	Load wheels axle to fork face (forks lowered)	x (mm)	1119	1119	1269
1.9	Wheelbase	y (mm)			
WEIGHT					
2.1	Truck weight without nominal load	kg	130	132	131
2.2	Axel load with nominal load & maximum battery weight, drive load/side	kg	560/1070	563/1069	563/1068
2.3	Axel load without nominal load & with maximum battery weight, drive load/side	kg	97/33	100/32	99/32
WHEELS, DRIVE TRAIN					
3.1	Wheel type: P=Polyurethane, N=Nylon, R=Rubber	P	P	P	P
3.2	Wheel dimension, drive side	(mm)	210	210	210
3.3	Wheel dimension, load side	(mm)	80	80	80
3.5	Number of wheels, drive/load side (x=driven)		1x+2/4	1x+2/4	1x+2/4
DIMENSIONS					
4.4	Lift height	h3 (mm)	110	110	110
4.9	Height of tiller arm / steering console (min. / max.)	h14 (mm)	635/1200	635 / 1200	635 / 1200
4.15	Fork height fully lowered	h13 (mm)	80	80	80
4.19	Overall length	l1 (mm)	1473	1473	1623
4.20	Length to fork face	l2 (mm)	473	473	473
4.21	Overall width	b1/b2 (mm)	550	685	550
4.22	Fork dimensions (thickness, width and length)	s / e / l (mm)	45 / 160 / 1000	45 / 160 / 1000	45 / 160 / 1150
4.25	Outside width over forks (minimum / maximum)	b5 (mm)	550	685	550
4.32	Ground clearance at centre of wheelbase (forks lowered)	m2 (mm)	35	35	35
4.33b	Working aisle width (Ast3) with 1000 x 1200 pallets, load crosswise	Ast3 (mm)	2106	2106	2226
4.34b	Working aisle width (Ast3) with 800 x 1200 pallets, load lengthwise	Ast3 (mm)	2038	2038	2095
4.35	Turning circle radius	Wa (mm)	1274	1274	1424
PERFORMANCE					
5.1	Travel speed, with / without load	km / h	4.8/5	4.8/5	4.8/5
5.2	Lifting speed, with / without load	m / s	30/35	30/35	30/35
5.3	Lowering speed, with / without load	m / s	Manual control	Manual control	Manual control
5.8	Maximum gradeability, with / without load	%	5/20	5/20	5/20
ELECTRIC MOTORS					
6.1	Rated power of lifting motor (Drive motor capacity [60 min. short duty])	kW	0.8	0.8	0.8
6.2	Rated power of travel motor (Lift motor output at 15% duty factor)	kW	0.65	0.65	0.65
6.4	Battery voltage / capacity	V / Ah	48/20	48 / 20	48 / 20
6.5	Battery weight	kg	8.5	8.5	8.5
6.6b	Energy consumption according to VDI cycle	kWh/h	0.15	0.15	0.15
MISCELLANEOUS					
10.7	Level of noise at the ear level of the driver according to EN 12 053:2001 and EN ISO 4871 in work LpAZ	dB (A)	70	70	70

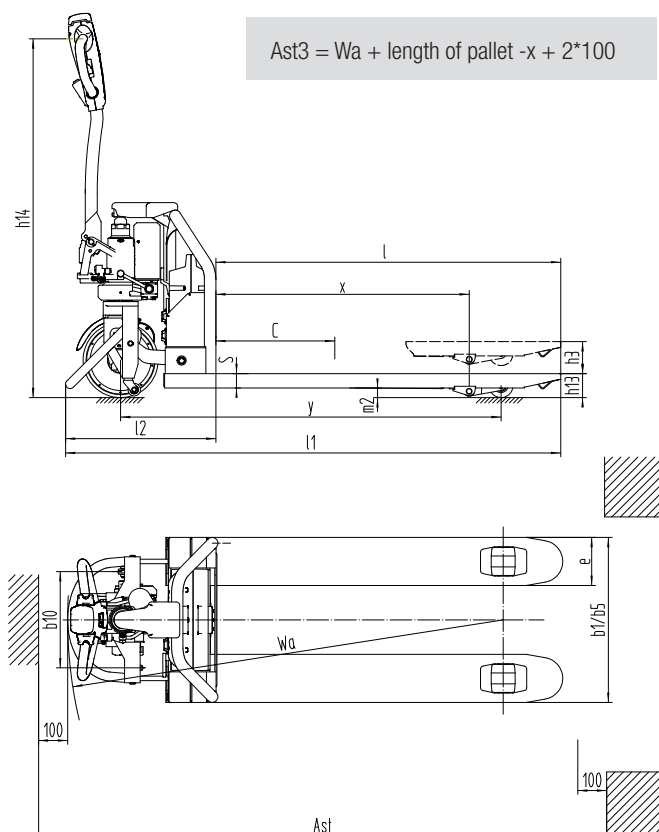

PEDESTRIAN ELECTRIC HAND PALLET TRUCK, 48V LI-ION **TPDL15E** 1.5 tonnes

VDI - PERFORMANCE & DIMENSIONS

CHARACTERISTICS				Towmotor	Towmotor	Towmotor
1.1	Manufacturer (abbreviation)			TPDL15EHPTP	TPDL15EKPTP	TPDL15EJPTP
1.2	Manufacturer's model designation			685 X1150	550 X1220	680 X1220
1.3	Power source: (battery, diesel, LP gas, petrol)			Battery	Battery	Battery
1.4	Operator type: pedestrian, operator standing, operator seated			Pedestrian	Pedestrian	Pedestrian
1.5	Load capacity	Q (kg)		1500	1500	1500
1.6	Load center distance	c (mm)		600	600	600
1.8	Load wheels axle to fork face (forks lowered)	x (mm)		1022	1022	952
1.9	Wheelbase	y (mm)		1339	1339	1269
WEIGHT						
2.1	Truck weight without nominal load		kg	133	135	130
2.2	Axel load with nominal load & maximum battery weight,drive load/side		kg	564/1069	565/1070	561/1069
2.3	Axel load without nominal load & with maximum battery weight,drive load/side		kg	101/32	102/33	98/32
WHEELS, DRIVE TRAIN						
3.1	Wheel type: P=Polyurethane, N=Nylon, R=Rubber			P	P	P
3.2	Wheel dimension, drive side		(mm)	210	210	210
3.3	Wheel dimension, load side		(mm)	80	80	80
3.5	Number of wheels, drive/load side (x=driven)			1x+2/4	1x+2/4	1x+2/4
DIMENSIONS						
4.4	Lift height	h3 (mm)		110	110	110
4.9	Height of tiller arm / steering console (min. / max.)	h14 (mm)		635 / 1200	635 / 1200	635 / 1200
4.15	Fork height fully lowered	h13 (mm)		80	80	80
4.19	Overall length	l1 (mm)		1693	1693	1623
4.20	Length to fork face	l2 (mm)		473	473	473
4.21	Overall width	b1/b2 (mm)		550	685	550
4.22	Fork dimensions (thickness, width and length)	s / e / l1 (mm)		45 / 160 / 1220	45 / 160 / 1220	45 / 160 / 1150
4.25	Outside width over forks (minimum / maximum)	b5 (mm)		550	685	550
4.32	Ground clearance at centre of wheelbase (forks lowered)	m2 (mm)		35	35	35
4.33b	Working aisle width (Ast3) with 1000 x 1200 pallets, load crosswise	Ast3 (mm)		2294	2294	2226
4.34b	Working aisle width (Ast3) with 800 x 1200 pallets, load lengthwise	Ast3 (mm)		2132	2132	2095
4.35	Turning circle radius	Wa (mm)		1494	1494	1424
PERFORMANCE						
5.1	Travel speed, with / without load		km / h	4.8/5	4.8/5	4.8/5
5.2	Lifting speed, with / without load		m / s	30/35	30/35	30/35
5.3	Lowering speed, with / without load		m / s	Manual control	Manual control	Manual control
5.8	Maximum gradeability, with / without load		%	5/20	5/20	5/20
ELECTRIC MOTORS						
6.1	Rated power of lifting motor (Drive motor capacity [60 min. short duty])		kW	0.8	0.8	0.8
6.2	Rated power of travel motor (Lift motor output at 15% duty factor)		kW	0.65	0.65	0.65
6.4	Battery voltage / capacity		V / Ah	48 / 20	48 / 20	48 / 20
6.5	Battery weight		kg	8.5	8.5	8.5
6.6b	Energy consumption according to VDI cycle		kWh/h	0.15	0.15	0.15
MISCELLANEOUS						
10.7	Level of noise at the ear level of the driver according to EN 12 053:2001 and EN ISO 4871 in work LpAZ		dB (A)	70	70	70

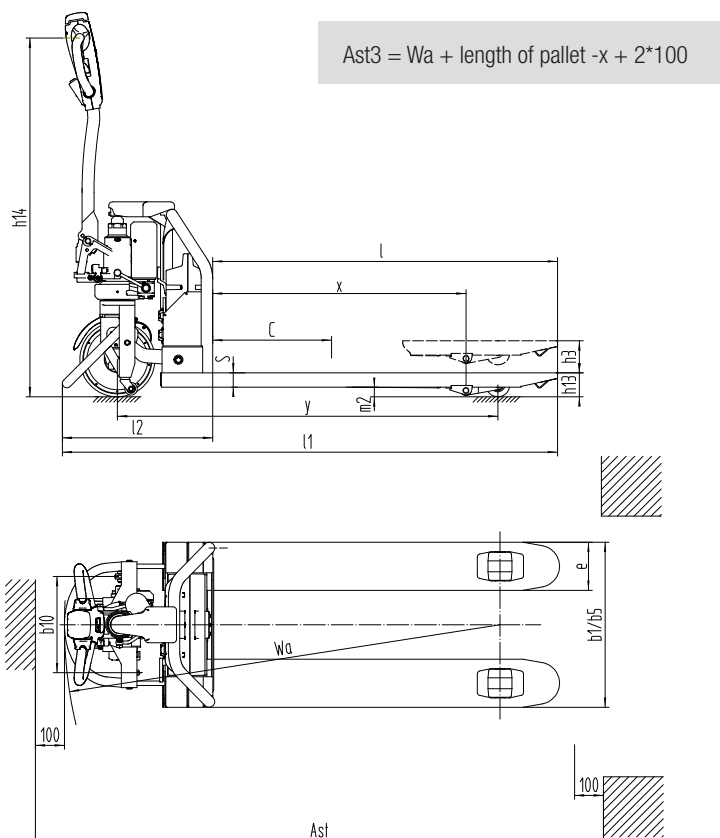

Continuing improvement may lead to changes in these specifications

PEDESTRIAN ELECTRIC PALLET TRUCK

TPD15E

1.5 tonnes

SMALL BUT STRONG



The Towmotor TPD15E Pedestrian Electric Pallet Truck is an all-rounder designed for basic to medium intensity indoor material handling applications up to 1.5 tonnes. Ideal for workshops, retail, small supermarkets and general warehousing, it's also the perfect solution for applications with limited space such as cargo containers.

EFFICIENCY

Working effortlessly and efficiently in the smallest of spaces, its very compact dimensions and intuitive controls make the TPD15E flexible and easy to use.

MANEUVERABILITY

The TPD15E is designed around the needs of the operator and offers unrivalled maneuverability through its compact dimensions and very small turning radius.

PRODUCTIVITY

Engineered to deliver maximum productivity with minimum cost of ownership, the high quality construction gives a stable and durable platform. Its suitability for mid-distance runs makes the truck highly flexible and further enhances productivity.

KEY FEATURES

Performance & Safety

- Automatic stop on gradients and ramps (automatic parking brake).
- Activation via key switch.
- Ergonomic tiller handle.
- Foot protection with just 35 mm ground clearance.
- Small turning radius.
- Extremely compact and stable construction.
- IP classification and protection, IP34 (indoor use).
- Carries the 'CE' mark of European Conformity.

Reliability & Easy Servicing

- Integrated charger can be used with every standard 230V socket.
- Maintenance-free GEL battery.
- One piece front cover for easy battery access during service and maintenance.
- High quality Curtis controller.

Efficiency & Ergonomics

- Caster support wheels for greater stability.
- Tandem load rollers.
- Tiller head integrated drive and operating switches with easy reach positions.
- Clearly positioned battery discharge indicator.



PEDESTRIAN ELECTRIC PALLET TRUCK TPD15E 1.5 tonnes

VDI - PERFORMANCE & DIMENSIONS



CHARACTERISTICS		
1.1	Manufacturer	Towmotor
1.2	Manufacturer's model designation	TPD15E
1.3	Power source	Battery
1.4	Operator type	Pedestrian
1.5	Load capacity	Q (kg) 1500
1.6	Load center distance	c (mm) 600
1.8	Load wheel axle to fork face (forks lowered)	x (mm) 955/1025
1.9	Wheelbase	y (mm) 1287/1357
WEIGHT		
2.1	Truck weight without load, with maximum battery weight	kg 181
WHEELS, DRIVE TRAIN		
3.1	Tyres: PT=Power Thane, Vul=Vulkollan, P=Polyurethane, N=Nylon, R=Rubber drive/load side	P
3.2	Tyre dimensions, drive side	(mm) Ø195x70
3.3	Tyre dimensions, load side	(mm) Ø80/Ø74
3.4	Castor wheel dimensions (diameter x width)	(mm) Ø44
3.5	Number of wheels, load/drive side (x=driven)	1X-2/2(4)
3.6	Track width (center of tyres), drive side	b10 (mm) 284
3.7	Track width (center of tyres), load side	b11 (mm) 360/390/525
DIMENSIONS		
4.4	Lift height	h3 (mm) 190/180
4.9	Height of tiller arm / steering console (min./max.)	h14 (mm) 700/1250
4.19	Overall length	l1 (mm) 1654/1724
4.20	Length to fork face	l2 (mm) 504
4.21	Overall width	b1/b2 (mm) 685/562
4.22	Fork dimensions (thickness, width, length)	s / e / l (mm) 53/160/1150(1220)
4.25	Outside width over forks (minimum/maximum)	b5 (mm) 520/550/685
4.32	Ground clearance at center of wheelbase, (forks lowered)	m2 (mm) 32/22
4.33a	Working aisle width (Ast) with 1000 x 1200 mm pallets, load crosswise	Ast (mm) 2260/2328
4.34a	Working aisle width (Ast) with 800 x 1200 mm pallets, load lengthwise	Ast (mm) 2128/2365
4.35	Turning radius	Wa (mm) 1454/1524
PERFORMANCE		
5.1	Travel speed, with/without load	km/h 4.3/4.8
5.2	Lifting speed, with/without load	m/s 0.02/0.03
5.3	Lowering speed, with/without load	m/s 0.035/0.025
5.8	Maximum gradeability, with/without load	% 5/20
ELECTRIC MOTORS		
6.1	Drive motor capacity (60 min. short duty)	kW 0.65
6.2	Lift motor output at 15% duty factor	kW 0.8
6.4	Battery voltage/capacity at 5-hour discharge	V /Ah 24/50
6.5	Battery weight	kg 12
	Battery dimension (LXWXH)	(mm) 244X180X231
MISCELLANEOUS		
10.7.1	Level of noise at the ear level of the driver according to EN 12 053:2001 and EN ISO 4871, drive/lift/idle LpAZ	dB(A) 70

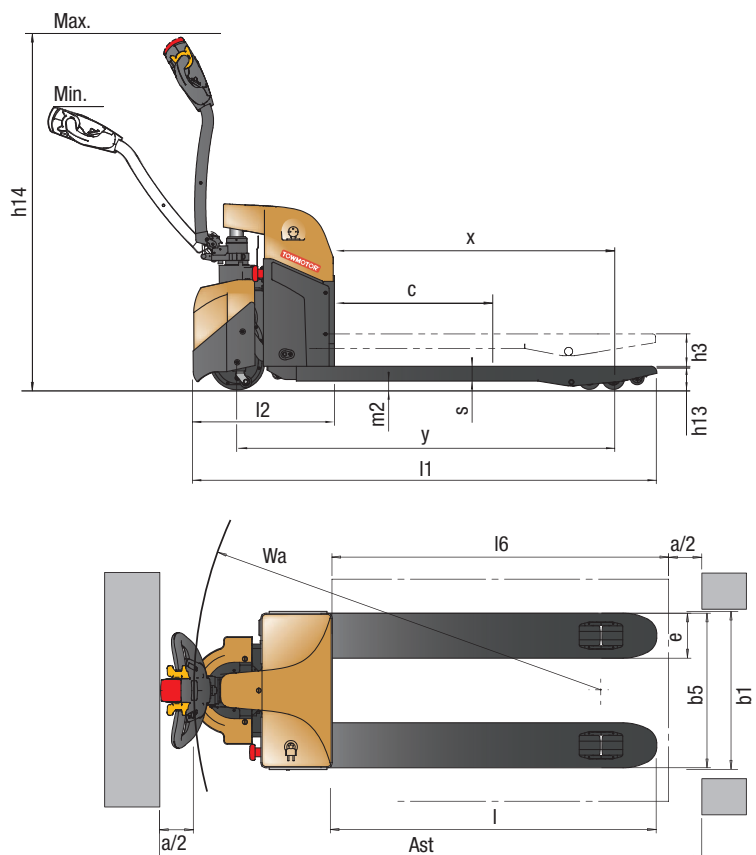

$Ast = Ast = Wa - x + l6 + a$
 $a = \text{Safety clearance (200 mm)}$
 $l6 = \text{Pallet length}$

PEDESTRIAN ELECTRIC PALLET TRUCK

TPD18E

1.8 tonnes

NO COMPROMISE ON QUALITY



While our warehouse products have an affordable price, that doesn't mean you need to compromise on quality or performance. They are designed to be robust and durable and give many years of service with minimal maintenance requirements

For ease of use, the ergonomic tiller arm with its butterfly controls can be used in an upright position for really tight spaces in a wide range of applications. This helps make it the ideal warehouse assistant in light duty applications.

KEY FEATURES

- 1,800 kg load capacity
- Low maintenance AC drive motor
- Lead-acid battery 160Ah
- Battery level indicator and operating hours meter (BDI)
- Side battery extraction
- Curtis controller
- Ergonomic and durable Curtis tiller-handle for maximum operator comfort
- External charger
- Compact design



EASY TO ADJUST FORK LEVERAGE

The strong forks, constructed from heavy-gauge steel are easy to adjust via conveniently located bolts.



OPTIMAL TRACTION

The internal suspension system design ensures that the drive wheel is under an even load regardless of operating conditions, providing optimal traction.

PEDESTRIAN ELECTRIC PALLET TRUCK TPD18E 1.8 tonnes

VDI - PERFORMANCE & DIMENSIONS

CHARACTERISTICS			
1.1	Manufacturer		Towmotor
1.2	Manufacturer's model designation		TPD18E
1.3	Power source: (battery, diesel, LP gas, petrol)		Electric (battery)
1.4	Operator type: pedestrian, (operator)-standing, -seated		Pedestrian
1.5	Load capacity	Q (kg)	1800
1.6	Load center distance	c (mm)	600
1.8	Load wheel axle to fork face (forks lowered)	x (mm)	934
1.9	Wheelbase	y (mm)	1277
WEIGHT			
2.1	Truck weight with load, with maximum battery weight	kg	520
2.2	Axle loadings with nominal load & maximum battery weight, drive/load side	kg	720/1600
2.3	Axle loadings without load & with maximum battery weight, drive/load side	kg	420/100
WHEELS, DRIVE TRAIN			
3.1	Tyres: PT=PowerThane, Vul=Vulkollan, drive/load side		PU/PU
3.2	Tyre dimensions, drive side	(mm)	250X70
3.3	Tyre dimensions, load side	(mm)	Single = 82X98 (Tandem = 80x70)
3.4	Castor wheel dimensions (diameter x width)	(mm)	114X60
3.5	Number of wheels, load/drive side (x=driven)	(mm)	1X+2/2 (4)
3.6	Track width (center of tyres), drive side	b10 (mm)	476
3.7	Track width (center of tyres), load side	b11 (mm)	400/532
DIMENSIONS			
4.6	Lift height	h5 (mm)	120
4.15	Fork height, fully lowered	h13 (mm)	82
4.9	Height of tiller arm / steering console (min./max.)	h14 (mm)	780/1230
4.19	Overall length	l1 (mm)	1651 (1150)
4.20	Length to fork face	l2 (mm)	500
4.21	Overall width	b1 (mm)	682
4.22	Fork dimensions (thickness, width, length)	s / e / l (mm)	54x150x1150 (1000/1220)
4.25	Overall width of forks	b5 (mm)	520(550/685)
4.32	Ground clearance at center of wheelbase, (forks lowered)	m2 (mm)	28
4.33a	Working aisle width (Ast) with 1000 x 1200 mm pallets, load crosswise (forks raised)	Ast (mm)	2237 (1150)
4.34a	Working aisle width (Ast) with 800 x 1200 mm pallets, load lengthwise (forks raised)	Ast (mm)	2114 (1150)
4.35	Turning radius	Wa (mm)	1434 (1150)
PERFORMANCE			
5.1	Travel speed, with/without load	km/h	6/6
5.2	Lifting speed, with/without load	m/s	0.06/0.11
5.3	Lowering speed, with/without load	m/s	0.12/0.13
5.8	Gradeability, with/without load	%	8/20
5.1	Service brake		ELECTRO MAGNETIC
ELECTRIC MOTORS			
6.1	Drive motor capacity (60 min. short duty)	kW	1.2
6.2	Lift motor output at 15% duty factor	kW	1.2
6.4	Battery voltage/capacity at 5-hour discharge	V /Ah	24/160
6.5	Battery weight	kg	170
	Battery dimension (LXWXH)	(mm)	645X148X560
MISCELLANEOUS			
10.7.1	Level of noise at the ear level of the driver according to EN 12 053:2001 and EN ISO 4871, drive/lift/idle LpAZ	dB(A)	70
10.7.3	Hand-arm vibration (EN 13 059:2002)		< 2.5
	Battery Charger	A/Ah	24/20

Continuing improvement may lead to changes in these specifications

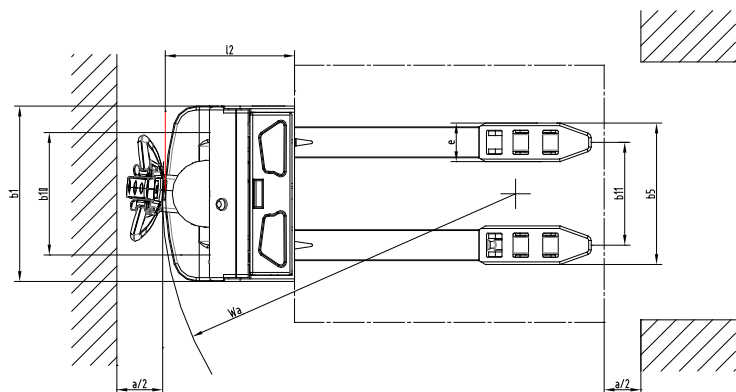
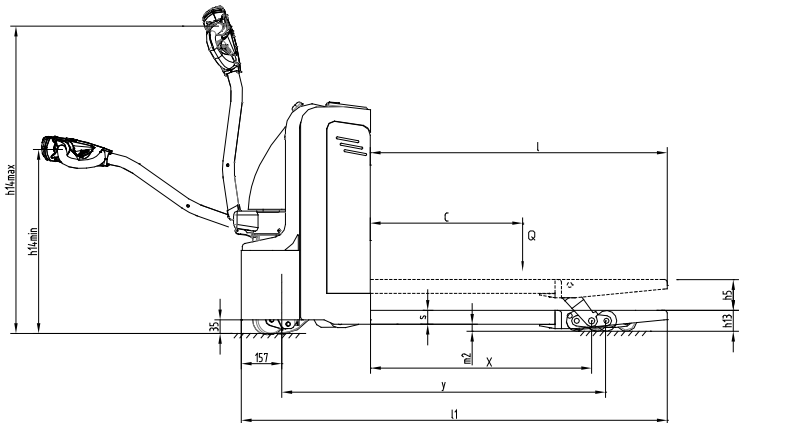

$Ast = Wa - x + l6 + 200$
 $Ast =$ Working aisle width
 $Wa =$ Turning radius
 $a =$ Safety clearance = 2×100 mm
 $R = \sqrt{(l6 + x)^2 + (b12 / 2)^2}$
 $l6 =$ Pallet length (800 or 1000 mm)
 $b12 =$ Pallet width (1200 mm)

ELECTRIC PALLET TRUCK WITH FOLDING PLATFORM & POWER STEERING

TPD20(L)ER

2.0 tonnes

COMFORTABLE & EFFECTIVE

Fast, simple and powerful, but safe and easy-to-use for all your horizontal pallet transport needs in a wide range of light and medium duty applications. The standard Creep speed button ensures high maneuverability in confined areas when operating at low speeds with the tiller in the upright position.

The standard EPS Power Steering makes the truck highly maneuverable while its Curve control 'Corner control' system reduces speed automatically when cornering for safe and stable operation.

KEY FEATURES

- 2.000 kg load capacity
- Electric Power Steering (EPS)
- Low maintenance AC drive motor
- Lead-acid battery 210Ah (li-ion optional)
- Battery level indicator and operating hours meter (BDI)
- Curtis controller
- Side battery extraction
- Ergonomic and durable Curtis tiller-handle for maximum operator comfort
- External charger
- Key switch
- Belly switch on tiller head
- Compact design

Li-ion
OPTIONAL



AC **EPS**

MPB20LER: LI-ION ADVANTAGES

- **Longer life** – 3 to 4 times lead-acid lifespan – reduces overall battery investment.
- **Higher efficiency** – energy losses during charging and discharging are around 30% lower, so electricity consumption is reduced.
- **Longer runtime** – thanks to higher energy capacity, lower losses and more efficient recovery of current from regenerative braking.
- **Consistently high performance** – with a more constant voltage curve – maintains greater truck productivity, even toward the end of a shift.
- **Faster charging and opportunity charging** – full charge within 1 to 2 hours – enables top-ups during short breaks, without damaging the battery or shortening its lifespan.
- **No battery changing** – fast opportunity charges enable continuous operation with just one battery and minimise the need to buy, store and maintain spares.
- **No maintenance** – the battery stays on board the truck for charging and there is no need for top-ups or electrolyte checks.
- **No gas** – avoids the space, equipment and running costs of a battery room and ventilation system.
- **Inbuilt protection** – intelligent battery management system (BMS) automatically prevents excessive discharge, charge, voltage and temperature, as well as virtually eliminating application errors.
- **Greater safety** – no explosive gas, acid spills or regular battery lifting.
- **Smaller carbon footprint** – better efficiency means less energy consumption, while longer life lowers the requirement for manufacture of additional batteries.



DURABLE STEERING SYSTEM

A direct-drive steering system employing gear wheels rather than belt and pulley means minimal maintenance and reliable operation.



EASY TO ADJUST FORK LEVERAGE

The strong forks, constructed from heavy-gauge steel are easy to adjust via conveniently located bolts.



OPTIMAL TRACTION

The internal suspension system design ensures that the drive wheel is under an even load regardless of operating conditions, providing optimal traction.

VDI - PERFORMANCE & DIMENSIONS

CHARACTERISTICS				
1.1	Manufacturer		Towmotor	Towmotor
1.2	Manufacturer's model designation		TPD20ER	TPD20LER
1.3	Power source: (battery, diesel, LP gas, petrol)		Electric (battery)	Electric (battery)
1.4	Operator type: pedestrian,(operator)-standing, -seated		Pedestrian	Pedestrian
1.5	Load capacity	Q (kg)	2000	2000
1.6	Load center distance	c (mm)	600	600
1.8	Load wheel axle to fork face (forks lowered)	x (mm)	964 (1150)	964
1.9	Wheelbase	y (mm)	1261 (1150)	1261
WEIGHT				
2.1	Truck weight with load, with maximum battery weight	kg	710	593
2.2	Axle loadings with nominal load & maximum battery weight, drive/load side	kg	1300/1410	1300/1410
2.3	Axle loadings without load & with maximum battery weight, drive/load side	kg	600/110	600/110
WHEELS, DRIVE TRAIN				
3.1	Tyres: PT=Power Thane, Vul=Vulkollan, P=Polyurethane, N=Nylon, R=Rubber drive/load side		P/P	P
3.2	Tyre dimensions, drive side	(mm)	250X70	250X80
3.3	Tyre dimensions, load side	(mm)	Single = 82X126 (Tandem = 82x98)	82X98(126)
3.4	Castor wheel dimensions (diameter x width)	(mm)	127X57	127X57
3.5	Number of wheels, load/drive side (x=driven)	(mm)	1X+2/2 (4)	1X+2/2(4)
3.6	Track width (center of tyres), drive side	b10 (mm)	490	537
3.7	Track width (center of tyres), load side	b11 (mm)	340/370/470/505	340/370/470/505
DIMENSIONS				
4.4	Lift height	h5 (mm)	120	120
4.9	Height of tiller arm / steering console (min./max.)	h14 (mm)	1150/1430	1050/1450
4.15	Fork height, fully lowered	h13 (mm)	82	82
4.19	Overall length	l1 (mm)	1760 (1150)	1760
4.20	Length to fork face	l2 (mm)	610/1072	610/1072
4.21	Overall width	b1 (mm)	775	775
4.22	Fork dimensions (thickness, width, length)	s / e / l (mm)	54X180X1100(1150/1220)	54X180X1150
4.25	Overall width of forks	b5 (mm)	520/550/650/685	520/550/650/685
4.32	Ground clearance at center of wheelbase, (forks lowered)	m2 (mm)	28	28
4.33c	Working aisle width (Ast) with 1000 x1200 mm pallets, load crosswise, platform up/down	Ast (mm)	1960 (1150)	1960
4.34c	Working aisle width (Ast) with 800 x1200 mm pallets, load lengthwise, platform up/down	Ast (mm)	2010 (1150)	2010
4.35	Turning radius	Wa (mm)	1600 (1150)	1600
PERFORMANCE				
5.1	Travel speed, with/without load (pedestrian)	km/h	4.7/4.8	7/7.1
5.1	Travel speed, with/without load (stand-on)	km/h	7.0/7.1	4.7/4.8
5.2	Lifting speed, with/without load	m/s	0.039/0.056	0.025/0.035
5.3	Lowering speed, with/without load	m/s	0.064/0.050	0.035/0.030
5.8	Gradeability, with/without load	%	6/12	8/20
5.10	Service brake		Electro Magnetic	Electro Magnetic
ELECTRIC MOTORS				
6.1	Drive motor capacity (60 min. short duty)	kW	1.5	1.5
6.2	Lift motor output at 15% duty factor	kW	1.2	1.2
6.4	Battery voltage/capacity at 5-hour discharge	V /Ah	24/210	24V/125AH
6.5	Battery weight	kg	170	60
	Battery dimension (LXWXH)	(mm)	750X170X534	700x176x564
MISCELLANEOUS				
	Battery type		Lead-acid	Lithium
8.1	Type of drive control		Curtis	Curtis
10.7.1	Level of noise at the ear level of the driver according to EN 12 053:2001 and EN ISO 4871, drive/lift/idle LpAZ	dB(A)	70	70
10.7.3	Hand-arm vibration (EN 13 059:2002)		< 2.5	< 2.5
	Battery Charger (external)	V/Ah	24/30	24/50

Continuing improvement may lead to changes in these specifications

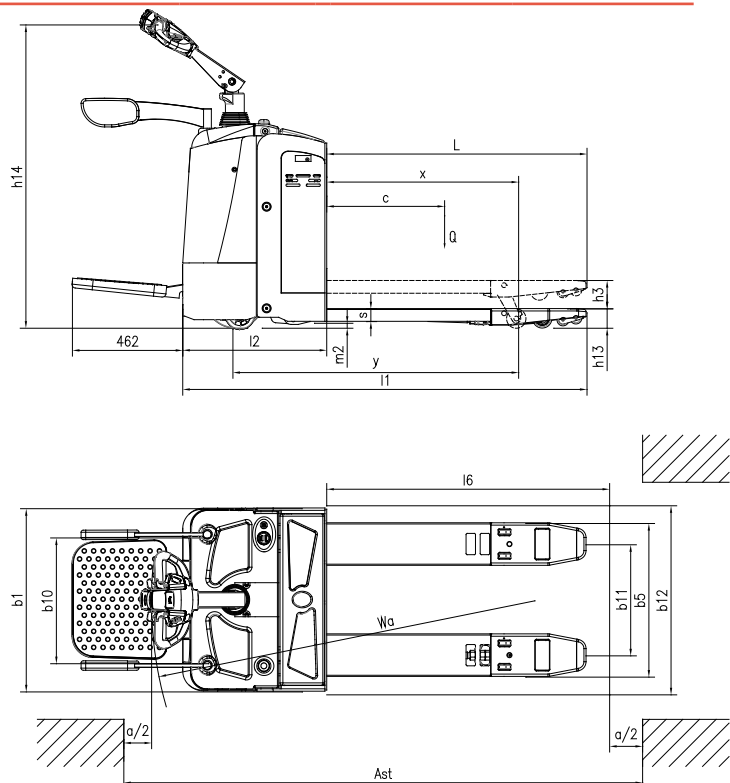

- Ast = Wa-x+l6+200
- Ast = Working aisle width
- Wa = Turning radius
- a = Safety clearance = 2 x 100 mm
- R = $\sqrt{(l6 + x)^2 + (b12 / 2)^2}$
- l6 = Pallet length (800 or 1000 mm)
- b12 = Pallet width (1200 mm)

PEDESTRIAN ELECTRIC MONO-MAST PALLET STACKER

TSD12EM

1.2 tonnes

Li-ion
OPTIONAL

COST EFFICIENT STORAGE

Designed for use in a wide variety of short lift height, light duty applications, our Mono-Mast Pallet Stackers always give a clear view forward. With the centrally installed open mono-mast, excellent visibility is assured.

The creep speed button ensures high maneuverability in confined areas when operating at low speeds with the tiller in the upright position.

As standard the truck is equipped with Initial Lift, meaning that two pallets can be lifted and transported simultaneously.

KEY FEATURES

- 1,200 kg load capacity
- Different lifting heights depending on model up to 1.95 m
- Low maintenance AC drive motor
- Low maintenance gel battery 105Ah
- Battery level indicator and operating hours meter (BDI)
- Curtis controller
- Ergonomic and durable Curtis tiller-handle for maximum operator comfort
- Initial Lift included
- Built-in charger
- Compact design



INITIAL LIFT AS STANDARD



PEDESTRIAN ELECTRIC MONO-MAST PALLET STACKER TSD12EM 1.2 tonnes

VDI - PERFORMANCE & DIMENSIONS

CHARACTERISTICS			
1.1	Manufacturer		Towmotor
1.2	Manufacturer's model designation		TSD12EM-1.6, 1.95M
1.3	Power source: (battery, diesel, LP gas, petrol)		Electric (battery)
1.4	Operator type: pedestrian, (operator)-standing, -seated		Pedestrian
1.5	Load capacity	Q (kg)	1200
1.6	Load center distance	c (mm)	600
1.8	Load wheel axle to fork face (forks lowered)	x (mm)	812
1.9	Wheelbase	y (mm)	1272
WEIGHT			
2.1	Truck weight with load, with maximum battery weight		kg
2.2	Axle loadings with nominal load & maximum battery weight, drive/load side		kg
2.3	Axle loadings without load & with maximum battery weight, drive/load side		kg
WHEELS, DRIVE TRAIN			
3.1	Tyres: PT=PowerThane, Vul=Vulkollan, drive/load side		PU/PU
3.2	Tyre dimensions, drive side	(mm)	195X70
3.3	Tyre dimensions, load side	(mm)	80X70
3.4	Castor wheel dimensions (diameter x width)	(mm)	150X60
3.5	Number of wheels, load/drive side (x=driven)	(mm)	1X+1/4
3.6	Track width (center of tyres), drive side	b10 (mm)	523
3.7	Track width (center of tyres), load side	b11 (mm)	390
DIMENSIONS			
4.2	Height with mast lowered	h1 (mm)	2050/2400
4.4	Lift height	h3 (mm)	1600/1950
4.5	Height with mast extended	h4 (mm)	2060/2410
4.6	Initial lift	h5 (mm)	120
4.15	Fork height, fully lowered	h13 (mm)	90
4.19	Overall length	l1 (mm)	1690/1770
4.2	Length to fork face	l2 (mm)	619
4.21	Overall width	b1 (mm)	800
4.22	Fork dimensions (thickness, width, length)	s / e / l (mm)	60/180/1070(1150)
4.25	Overall width of forks	b5 (mm)	570
4.32	Ground clearance at center of wheelbase, (forks lowered)	m2 (mm)	17 - 137
4.33	Working aisle width (Ast) with 1000 x1200 mm pallets, load crosswise, platform up/down	Ast (mm)	2286
4.34	Working aisle width (Ast) with 800 x1200 mm pallets, load lengthwise, platform up/down	Ast (mm)	2224
4.35	Turning radius	Wa (mm)	1450
PERFORMANCE			
5.1	Travel speed, with/without load	km/h	4.5/5
5.2	Lifting speed, with/without load	m/s	0.06/0.13
5.3	Lowering speed, with/without load	m/s	0.13/0.10
5.8	Gradeability, with/without load	%	6/15
5.10	Service brake		ELECTRO MAGNETIC
ELECTRIC MOTORS			
6.1	Drive motor capacity (60 min. short duty)	kW	0.65
6.2	Lift motor output at 15% duty factor	kW	2.2
6.4	Battery voltage/capacity at 5-hour discharge	V /Ah	24v 105/120 (optional)
6.5	Battery weight	kg	60.8
	Battery dimension (LXWXH)	(mm)	329X172X214
MISCELLANEOUS			
8.4	Level of noise at the ear level of the driver according to EN 12053	dB(A)	70

Continuing improvement may lead to changes in these specifications

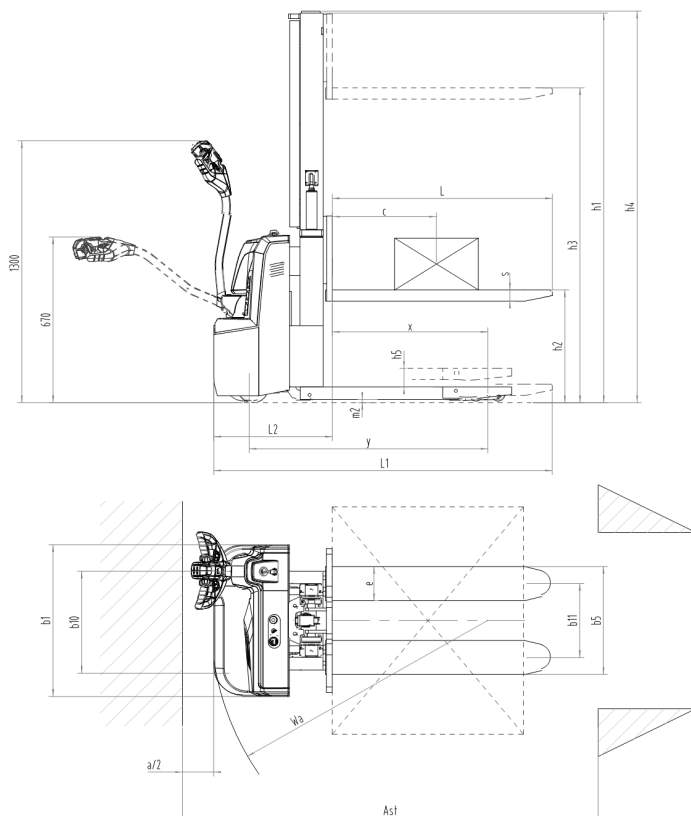

$Ast = Wa - x + l6 + 200$
 $Ast =$ Working aisle width
 $Wa =$ Turning radius
 $a =$ Safety clearance = 2 x 100 mm
 $R = \sqrt{(l6 + x)^2 + (b12 / 2)^2}$
 $l6 =$ Pallet length (800 or 1000 mm)
 $b12 =$ Pallet width (1200 mm)

PEDESTRIAN ELECTRIC TELESCOPIC-MAST PALLET STACKER

TSD12SM

1.2 tonnes

Li-ion
OPTIONAL

MAKING LIGHT WORK OF PALLET HANDLING

Designed for use in a wide variety of light duty applications, where greater lift height is required, our pallet stackers make light work of your warehouse tasks.

The creep speed button ensures high maneuverability in confined areas when operating at low speeds with the tiller in the upright position.

Equipped as standard with Initial Lift, meaning that two pallets can be lifted and transported simultaneously.

KEY FEATURES

- 1,200 kg load capacity
- Different lifting heights depending on model up to 3.0 m
- Low maintenance AC drive motor
- Low maintenance gel battery 105Ah
- Battery level indicator and operating hours meter (BDI)
- Curtis controller
- Ergonomic and durable Curtis tiller-handle for maximum operator comfort
- Initial Lift included
- Built-in charger
- Compact design



INITIAL LIFT AS STANDARD



PEDESTRIAN ELECTRIC TELESCOPIC-MAST PALLET STACKER TSD12SM 1.2 tonnes

VDI - PERFORMANCE & DIMENSIONS

CHARACTERISTICS			
1.1	Manufacturer		Towmotor
1.2	Manufacturer's model designation		TSD12SM, 1.6, 2.5, 3.0M
1.3	Power source: (battery, diesel, LP gas, petrol)		Electric (battery)
1.4	Operator type: pedestrian,(operator)-standing, -seated		Pedestrian
1.5	Load capacity	Q (kg)	1200
1.6	Load center distance	c (mm)	600
1.8	Load wheel axle to fork face (forks lowered)	x (mm)	788
1.9	Wheelbase	y (mm)	1268
WEIGHT			
2.1	Truck weight with load, with maximum battery weight	kg	710
2.2	Axle loadings with nominal load & maximum battery weight, drive/load side	kg	710/1000
2.3	Axle loadings without load & with maximum battery weight, drive/load side	kg	220/490
WHEELS, DRIVE TRAIN			
3.1	Tyres: PT=PowerThane, Vul=Vulkollan, drive/load side		PU/PU
3.2	Tyre dimensions, drive side	(mm)	195X70
3.3	Tyre dimensions, load side	(mm)	80X70
3.4	Castor wheel dimensions (diameter x width)	(mm)	150X60
3.5	Number of wheels, load/drive side (x=driven)	(mm)	1X+1/4
3.6	Track width (center of tyres), drive side	b10 (mm)	523
3.7	Track width (center of tyres), load side	b11 (mm)	390
DIMENSIONS			
4.1	Height with mast lowered	h1 (mm)	2122/1872/2122
4.2	Lift height	h3 (mm)	1600/2500/3000
4.3	Height with mast extended	h4 (mm)	2122/3092/3592
4.4	Initial lift	h5 (mm)	120
4.5	Fork height, fully lowered	h13 (mm)	90
4.6	Overall length	l1 (mm)	1709(1789)
4.7	Length to fork face	l2 (mm)	639
4.8	Overall width	b1 (mm)	800
4.9	Fork dimensions (thickness, width, length)	s / e / l (mm)	60/180/1070(1150)
4.10	Overall width of forks	b5 (mm)	570
4.11	Ground clearance at center of wheelbase, (forks lowered)	m2 (mm)	17 - 137
4.12	Working aisle width (Ast) with 1000 x1200 mm pallets, load crosswise, platform up/down	Ast (mm)	2286
4.13	Working aisle width (Ast) with 800 x1200 mm pallets, load lengthwise, platform up/down	Ast (mm)	2224
4.14	Turning radius	Wa (mm)	1450
PERFORMANCE			
5.1	Travel speed, with/without load	km/h	4.5/5
5.2	Lifting speed, with/without load	m/s	0.06/0.13
5.3	Lowering speed, with/without load	m/s	0.13/0.10
5.8	Gradeability, with/without load	%	6/15
5.10	Service brake		ELECTRO MAGNETIC
ELECTRIC MOTORS			
6.1	Drive motor capacity (60 min. short duty)	kW	0.65
6.2	Lift motor output at 15% duty factor	kW	2.2
6.3	Battery voltage/capacity at 5-hour discharge	V /Ah	24/105
6.4	Battery weight	kg	60.8
6.5	Battery dimension (LXWXH)	(mm)	329X172X214
MISCELLANEOUS			
8.4	Level of noise at the ear level of the driver according to EN 12053	dB(A)	70

Continuing improvement may lead to changes in these specifications

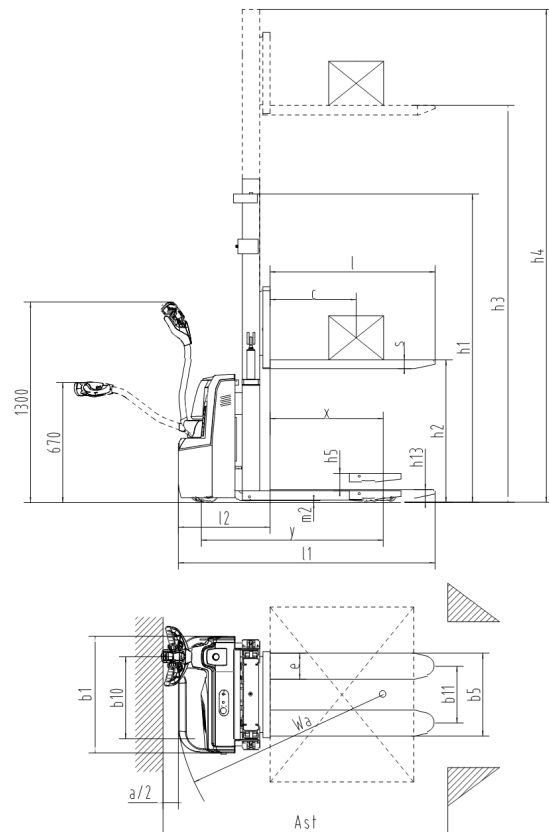

$Ast = Wa - x + l6 + 200$
 $Ast =$ Working aisle width
 $Wa =$ Turning radius
 $a =$ Safety clearance = 2×100 mm
 $R = \sqrt{(l6 + x)^2 + (b12 / 2)^2}$
 $l6 =$ Pallet length (800 or 1000 mm)
 $b12 =$ Pallet width (1200 mm)

MINI ORDER PICKER

TOD3E

150kg platform capacity, up to 3m lifting height

WHY STILL USE TRADITIONAL LADDERS?

The Towmotor order picker is a safer and more productive alternative to the traditional ladders commonly used in today's workplaces. The Towmotor order picker is designed with operator safety and ease of use in mind. This helps you increase productivity and efficiency in your warehouse while reducing the risk of injuries.

Amongst its many advantages are the extremely stable mast and its compact design. Furthermore, the vehicle's tight turning circle and easy fingertip controls make it the ideal and safe solution for light to medium volume order picking in shops, retail and warehouse applications.

The machine is also versatile enough for use in maintenance tasks up to a height of 3m.

COMPACT STRUCTURE

- Small footprint of 750mm and a low step-in allows flexibility in narrow aisles.
- Adjustable tray gives high visibility, meaning safe and efficient order picking.
- Solid mast structure and stable chassis allows safe load handling at maximum work height.
- low step-in allows easy platform entry.
- Polyurethane wheels for greater stability during load handling.

SAFETY

- Full platform sensing of operator presence. When gate is left open the truck will not lift or move.
- Hand sensors ensure the operator has both hands on the controls for normal travel and lift functions.
- Operator presence sensors which ensure the operator has both feet properly in a natural position on the platform, automatically stops travel and lift/lower functions if either foot is removed.
- Emergency stop button and horn.
- Automatically reduced speed (elevation control) at different heights.
- Anchor point for securing safety harness.

EASY CONTROL

- Creep speed function for very slow, safe and tight manoeuvres.
- Fingertip control.
- Key switch.
- BDI and hour meter.

KEY FEATURES

- Platform capacity (1 person permitted on platform) 150 kg.
- Fully electric, drivable at maximum height.
- Amber safety lights.
- Maximum platform lifting height 3 m.
- Maximum working height up to 5 m.
- Zapi controller.
- DC motor.
- Internal battery charger.
- Low Maintenance Gel Battery 24V/105Ah (optional 250Ah).
- Material-load tray capacity 90 kg.
- Drive speed 4.5 km/h, mast lowered.
- Towing device available as option.



MINI ORDER PICKER **TOD3E** 150kg platform capacity, up to 3m lifting height

VDI - PERFORMANCE & DIMENSIONS

CHARACTERISTICS			
1.1	Manufacturer		Towmotor
1.2	Manufacturer's model designation		TOD3E
1.3	Power source		Battery
1.4	Operator type		Standing
1.5	Load capacity	Q (kg)	90+150
1.9	Wheelbase	y (mm)	1145
WEIGHT			
2.1	Truck weight without load, with maximum battery weight	kg	750
	Load Capacity Operator Compartment	kg	150
	Rated load of material tray	kg	90
WHEELS, DRIVE TRAIN			
3.1	Tyres: PT=Power Thane, Vul=Vulkollan, P=Polyurethane, N=Nylon, R=Rubber drive/load side		P
3.2	Tyre dimensions, drive side	(mm)	250X60
3.4	Castor wheel dimensions (diameter x width)	(mm)	180X50
3.5	Number of wheels, load/drive side (x=driven)		2X/2
DIMENSIONS			
4.2a	Height with mast lowered	h1 (mm)	1590
4.6	Lift height	h5 (mm)	3000
4.5	Height with mast extended	h4 (mm)	4255
4.14	Platform height, raised	h12 (mm)	3000
4.19	Overall length	l1 (mm)	1500
4.21	Overall width	b1/b2 (mm)	750
4.35	Turning radius	Wa (mm)	1300
	Material-load tray dimension (length x width)	(mm)	700X500
PERFORMANCE			
5.1	Travel speed, with/without load	km/h	4.5
5.2	Lifting speed, with/without load	m/s	0.14
5.3	Lowering speed, with/without load	m/s	0.13
5.8	Maximum gradeability, with/without load	%	5
ELECTRIC MOTORS			
6.1	Drive motor capacity (60 min. short duty)	kW	0.5
6.2	Lift motor output at 15% duty factor	kW	2.2
6.4	Battery voltage/capacity at 5-hour discharge	V/Ah	24V/105 (250)
6.5	Battery weight	kg	52/70
	Battery dimension (LXWXH)	(mm)	260X168X217 (260X180X275)
MISCELLANEOUS			
8.1	Type of drive control		DC Zapi

Continuing improvement may lead to changes in these specifications

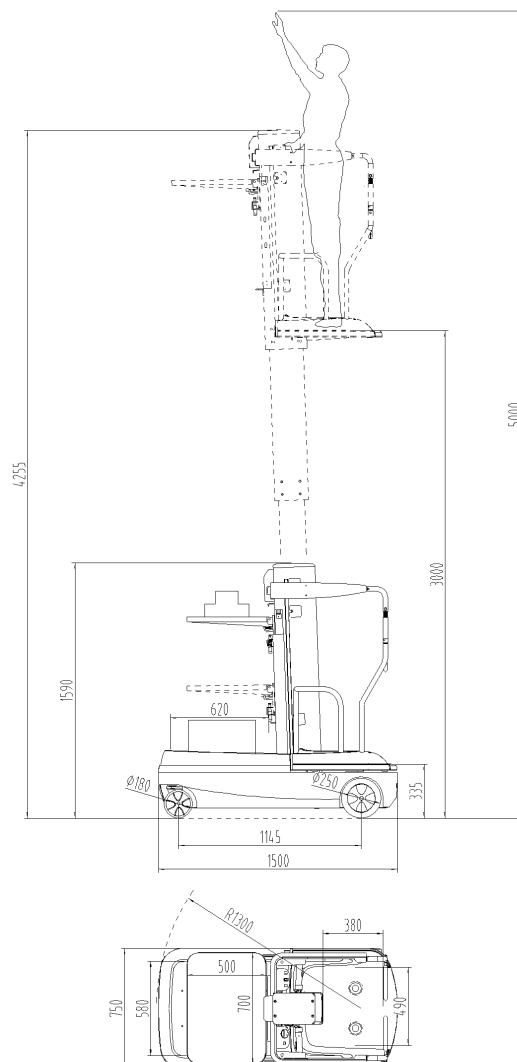

Wa = Turning radius
 a = Safety clearance = 2 x 100 mm
 $R = \sqrt{(l6 + x)^2 + (b12 / 2)^2}$
 l6 = Pallet length (800 or 1000 mm)
 b12 = Pallet width (1200 mm)

ELECTRIC TOW TRUCK

TTD30E, TTD60E

3.0 - 6.0 tonnes

UNPARALLELED RESILIENCE, UNBEATABLE TOUGHNESS

The robust Towmotor Tow Truck range exceeds expectations in applications that demand endurance over long travel distances. They are operated from a comfortable driver's seat and have the capacity to haul cargo goods for at least one work shift per charge.

Available in either 3.0t (TTD30E) or 6.0t (TTD60E) load capacities, the tow trucks are built with high ground clearance, allowing the operator to shuttle through both indoor and outdoor environments easily regardless of ground conditions or gradients.

With a maximum towing speed of 7.0km/h, they are the optimal choice to meet the toughest requirements - all while operating effectively and safely.

PERFORMANCE

- Smooth travel speed control up to 14km/hr (6t) when unladen.
- Powerful AC drive motor giving high performance.
- Side battery loading design allows easy battery interchange (optional on TTD30E only).

RELIABILITY & MAINTENANCE

- Quick release tow pins facilitate easy unlocking & locking of the tow hook.
- Heavy duty hood offers protection from impacts and from water ingress during light showers.
- Robust & maintenance-free AC traction motor allows smooth transitions from point to point.
- IP65 AC controller offers good protection against water & dust ingress.
- High-quality connectors and durable electrical harnesses.
- Standard Battery Discharge Indicator (BDI) shows operating hours, battery level and error code.
- Electric power steering (EPS) for effortless steering reduces operator fatigue (optional on TTD60E only).

SAFETY

- Safety seat switch ensures the operator is seated before starting the truck (optional).
- Electromagnetic braking system gives smooth, steady deceleration (standard on TTD30E, optional on TTD60E).
- Mechanical hand brake (Standard on the TTD60E).
- Standard combination lights give good forward illumination and alert nearby pedestrians of the truck's approach.
- Walk-beside buttons allow the operator to perform fine adjustments to align the rear tow eye position (optional).
- Partially enclosed cabin offers shelter from light rain (optional).
- Adjustable steering wheel for comfortable operation.

LIGHTING

- The lighting system includes:
 - Two front (LED*) headlights.
 - Two brake (LED*) lights.
 - Front and rear (LED*) indicators.
 - Reverse lights (LED*)

* Only for TTD60E

AC



ELECTRIC TOW TRUCK TTD30E, TTD60E 3.0 - 6.0 tonnes

VDI - PERFORMANCE & DIMENSIONS

CHARACTERISTICS				Towmotor	Towmotor
Manufacturer				TTD30E	TTD60E (AC)
Manufacturer's model designation				Battery	Battery
1.2	Power source		Seated	Seated	
1.3	Operator type		3000	6000	
1.4	Max. traction (60 minutes rated)	Q (kg)	750 / 75	1500 / 150	
1.5	Rated traction (60 minutes rated)	F (N / kg)	280 / 350	280 / 350	
1.7	Drawbar center height	h1/h2 (mm)	1055	1280	
1.9	Wheelbase	l1 (mm)			
WEIGHT					
2.1	Truck weight without load, with maximum battery weight	kg	780	1280	
2.2	Axle loadings with nominal load & maximum battery weight, drive/load side	kg	310	450	
2.3	Axle loadings without load & with maximum battery weight, drive/load side	kg	470	830	
WHEELS, DRIVE TRAIN					
3.1	Tyres: SR=Solid-rubber		Solid - rubber	Solid - rubber	
3.2	Tyre dimensions, drive side	(mm)	15*4 1/2-8	15*4 1/2-8	
3.3	Tyre dimensions, load side	(mm)	15*4 1/2-8	4.00-8	
3.5	Number of wheels, load/drive side (x=driven)	x= Driving wheels	1/2X	1/2X	
4.5	Tread, rear	w1	860	946	
	Rear hanging distance	l2 (mm)	382	450	
DIMENSIONS					
4.8	Seat- or stand height	h3 (mm)	910	910	
4.9	Overall height	h (mm)	1270	1250	
4.10	Approach angle $\alpha 1$	$^{\circ}$	$\geq 54^{\circ}$	$\geq 45^{\circ}$	
4.11	Departure angle $\alpha 2$	$^{\circ}$	$\geq 37^{\circ}$	$\geq 40^{\circ}$	
4.12	Min. ground height	x (mm)	90	100	
4.19	Overall length	L (mm)	1720	1940	
4.21	Overall width	W (mm)	968	1100	
4.35	Turning radius	Wa (mm)	1490	1650	
PERFORMANCE					
5.1 - 5.2	Travel speed, with/without load	km/h	6.5 / 10	7 / 14	
5.7 - 5.8	Maximum gradeability, with/without load	%	8 / 10	6 / 15	
5.10	Service brake		Mechanical/Hydraulic	Mechanical/Hydraulic	
ELECTRIC MOTORS					
6.1	Drive motor capacity (60 min. short duty)	kW	3	5	
6.4	Battery voltage/capacity	V/Ah	36 / 250	48 / 400	
6.5	Battery weight	kg	250	610	
MISCELLANEOUS					
8.1	Type of drive control		Mosfett	Mosfett	
8.2	Level of noise	dB(A)	68	68	
8.3	Traction bolt		Traction pin (26)	Traction pin (26)	



Continuing improvement may lead to changes in these specifications



STANDARD BDI

Battery Discharge Indicator (BDI) shows operating hours, battery level and error code.



ADJUSTABLE STEERING WHEEL

The steering wheel can be adjusted to suit the operator.

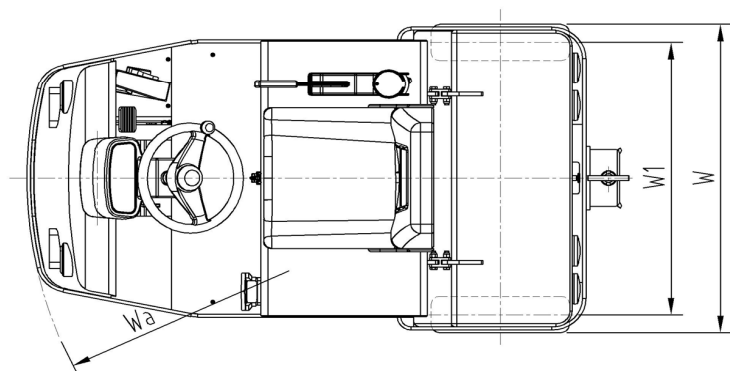
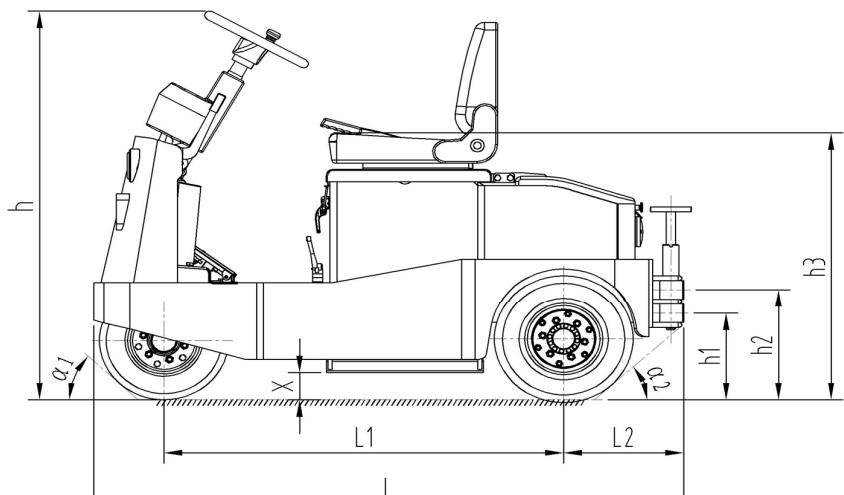

TOWMOTOR®



While high quality is paramount to Towmotor, we also maintain a trusted and reliable network of skilled professionals providing support to owners of Towmotor equipment. You will benefit not only from equipment that will provide years of trouble free service, but also gain the support of a team of experts who will be there should you ever need them. We call it 'Towmotor peace of mind'.

WWW.TOWMOTOR.EU

WEGT2046 (0121)
©2021, MLE B.V. All Rights Reserved.