



Service manual

SBP12QLMI

1	Safety Regulations	1
1.1	Disclaimer.....	2
1.2	Introduction.....	2
1.3	Regulatory compliance	2
1.4	Directional terms	2
1.5	Truck model covered in this manual	3
1.6	Safety regulations	3
1.7	Location of decals and machine plate	5
1.8	Climate conditions	6
1.9	Emergency procedures.....	7
1.10	Handling loads safely.....	7
1.11	Repairs and structural modifications	7
2	Vehicle Description	8
2.1	Overview	9
2.2	Machine plate	9
2.3	Load diagram.....	10
3	Vehicle Operation	11
3.1	Vehicle Operation	12
3.2	Daily checks before operation	12
3.3	Starting the truck	12
3.4	Tiller head.....	13
3.5	Fork lifting.....	13
3.6	Fork lowering	14
3.7	Driving forwards and backwards	14
3.8	Accelerating and braking.....	14
3.9	Emergency reversing.....	15
3.10	Slow speed travelling.....	15
3.11	Parking.....	15
3.12	Use, Maintenance and Charging of Storage Battery	15
3.13	Lithium-ion battery.....	16
3.14	Charger	20
4	Maintenance.....	22
4.1	Maintenance	23
4.2	Levels of maintenance	23
4.3	Routine maintenance.....	23
4.4	Level 1 maintenance	23
4.5	Level 2 maintenance	24
4.6	Instructions for ordering parts	24
4.7	Common failures and troubleshooting	24
4.8	Noise level.....	26
4.9	Hand-arm vibration.....	26
4.10	Solid particle and liquid ingress protection	26
4.11	Transportation of truck	26
4.12	Loading, unloading, transportation and storage of truck.....	27

Table of contents

4.13	Storing the truck	27
4.14	Long term storage	27
4.15	Hydraulic oil	28
4.16	Proper disposal of a decommissioned truck.....	28
4.17	Lifting the truck.....	28
5	Specifications	29
5.1	Truck data.....	30
6	Hydraulic Schematics	32
6.1	Hydraulic Schematics	33
7	Electric Schematics	34
7.1	Electric Schematics	35

1	SAFETY REGULATIONS	
1.1	Disclaimer.....	2
1.2	Introduction.....	2
1.3	Regulatory compliance.....	2
1.4	Directional terms.....	2
1.5	Truck model covered in this manual.....	3
1.6	Safety regulations.....	3
1.7	Location of decals and machine plate.....	5
1.8	Climate conditions.....	6
1.9	Emergency procedures.....	7
1.10	Handling loads safely.....	7
1.11	Repairs and structural modifications.....	7

1.1 Disclaimer

The content of this manual is protected by copyright law and may not be copied, fully or in part, without written permission.

The material has undergone careful examination with regard to correctness. We reserve the right to make changes.

This is a translation from the original English version of the publication; should any discrepancy in translation occur, refer to the original English publication for clarification.

© Copyright **MLE AB** (556083–6461), 2024



NOTE

Due to continuous design improvements and updates, some images in this publication may differ slightly from your truck.

1.2 Introduction

This stacker truck is designed and manufactured to lift and transport materials indoors. Please read this Operation and Maintenance Manual before operating or performing maintenance on the truck. After reading this manual, store it in a safe, dry place for later use.

MLE cannot anticipate every possible circumstance that might involve a potential hazard. The warnings in this Operation and Maintenance Manual and on the product are therefore not all-inclusive.

If a tool, procedure, work method or operating technique not specifically recommended by MLE is used, you must satisfy yourself that it does not pose a safety hazard to yourself and others. You should also ensure the product will not be damaged or made unsafe by the operation, lubrication, maintenance or repair procedures you choose.

All information, specifications and illustrations in this manual are based on the latest data available at the time of publication. The specifications, measurements, adjustments, illustrations and other items can change at any time. These changes can affect the service given to the product.

1.3 Regulatory compliance

MLE B.V. (33274459), Hefbrugweg 77, 1332 AM Almere, The Netherlands declares that this powered pallet truck meets the requirements of the Machinery Directive (2006/42/EC) and EMC Directive 2014/30/EU, and complies with EN ISO 3691-1:2015 + AC:2016 + A1:2020 and EN16307–1:2020 and thus has the CE marking

As regulations can vary from country to country, familiarize yourself with the regulations and standards valid in your country.

1.4 Directional terms

The directions “LEFT”, “RIGHT”, “FRONT” and “REAR” are given from the viewpoint of the operator facing forward with the tiller directly in front of them.

1.5 Truck model covered in this manual

The SBP12QLMI stacker truck – is an electric (battery) operated pedestrian stacker truck with a load and lifting capacity of 1200 kilograms.

1.6 Safety regulations



WARNING

Before using this truck, pay attention to the following items:

Authorized and trained operators only!

Do not operate this truck unless you know and have mastered the drive and operational features of the truck.

Do not operate this truck if you are under 18 years of age or are not in the possession of sufficient physical and mental abilities to operate the truck without any risks.

Do not lift or transport people!

Do not stand or ride on the forks.

Do not stand or ride on a load or pallet on the forks.

Do not place any part of your body between the tiller arm and the truck.

Operate only in approved areas!

Do not travel on public roads.

Do not use the truck in work areas that have insufficient lighting and visibility. The ambience lighting should be at least 50 lux. In areas that do not have sufficient lighting or visibility, use optional devices to improve the working conditions.

Make sure that the combined weight of the truck and the load does not exceed the bearing capacity of the floor.

Do not operate the truck in areas that contain hazardous flammable gases, liquids or other combustibles.

Do not operate the truck in cold storage warehouses, low temperature environments or areas with salt or other corrosive substances unless specifically equipped to do so.

Turn the key switch to the ON position only when the truck is in the normal operating position.

Do not operate a damaged or defective truck! If the truck is damaged, take it out of service until it has been restored to safe operating condition. Park it in a non-operating area and remove the key. Attach a "DO NOT OPERATE" or similar warning tag to the truck. Contact your authorized powered pallet truck dealer for repairs.

Do not allow any unauthorised persons in the work area where the truck is operated. A helper must not be near the truck. Personnel must be clear of the truck operating area. Watch out for pedestrians at all times! Yield the right-of-way to pedestrians at all times.

Do not move when someone is next to the truck! If someone is standing next to the truck, Do not proceed until they are at a safe distance. Do not assume that people are aware of you and will move out of your way.

Handle only stable and safely arranged loads! If a load is unstable, it could easily shift and fall on someone. Do not allow unloading from raised loads! Failure to follow this rule could cause serious injury.

The operator is required to slow down and activate the horn at aisle crossings and other locations where vision is obstructed.

Take care when passing another truck!

Do not pass another truck travelling in the same direction at intersections, blind spots or at other dangerous locations.

Do not indulge in stunt driving or horseplay! Stunt driving and horseplay is hazardous for both the truck operator and fellow workers.

- When operating with a load, either the load or the tip of the forks is hard to see.
- If operated carelessly, the load or forks could collide with nearby objects.
- When making a turn while operating in reverse with a load, always pay attention to the position of the load. If not, the load could collide with nearby objects.

Always look in the direction of travel! Travel in reverse if forward visibility is blocked! For better visibility with large loads, travel in reverse, but always keep a lookout in the direction of travel.

Travel safely on grades with a loaded truck!

When ascending or descending gradients, loaded trucks must be driven with the load facing up the gradient. Use care to reduce the risk of fork tips or the bottom of the pallet truck from touching the ground. Do not turn on a ramp or grade. Turning on a ramp or grade can cause the truck, loaded or unloaded, to turn over.

Always stay within the capacity!

Read the capacity plate to make sure a load is within the capacity of the truck before you handle the load. The maximum lifting capacity of the truck is 1500 kilograms and the weight of the load must not exceed the maximum lifting capacity.

Do not lift or transport people!

If you need to use an elevator, make sure that the combined weight of the truck, the load and yourself does not exceed the maximum load capacity of the elevator. Always drive the truck into elevators and any other narrow spaces with the load in front.

Do not wear loose clothing or accessories – flapping cuffs, dangling chains, neckties, scarves or rings – that could catch in moving parts. Wear personal protective clothing or equipment appropriate for the conditions of your work places.

Do not perform any of the following which could affect safe operation:

- Transport or lift people
- Use the truck as a mounting surface
- Use the truck as an access board or a ladder
- Tow another truck
- Push, drag or side-shift loads that lie on the ground
- Drive with hanging loads
- Drive with swinging loads
- Drive inattentively
- Drive while physically or mentally incapacitated
- Drive while under the influence of intoxicating substances
- Drive while listening to music through a headset
- Drive while drinking, eating or smoking
- Drive while using a cell phone or while texting

Be careful of forks that extend beyond the load! If the forks extend beyond the load, use extra caution. Make sure the fork tips do not make contact with other materials.

Check work places for high risk! When working on docks, ramps, platforms and other high risk areas, use adequate blocks to reduce the risk of the truck from falling off.

Slow down for wet and slippery surfaces!

- Loose or slippery materials such as sand, gravel, ice, mud, etc. on your operating surfaces could cause a skid or tip-over.
- Avoid the conditions or slow down.
- Keep your operating surfaces clean and dry at all times.
- Wet spots could cause a skid or tip-over. You need a greater stopping distance on wet surfaces.
- Apply brakes earlier on slippery surfaces than on dry surfaces. DO NOT drive into a flooded area whenever possible.

Be aware of the stability of an empty truck; truck stability can be affected by:

- Dimensions, weight, shape and position of the load
- Height of the lifted load
- Angle of forward or backward tilt
- Dimensions and weight of the battery in the truck
- Dynamic forces that are caused when the lift truck turns or increases or decreases its speed
- Condition and grade of surfaces on which the lift truck operates
- Wind forces if the truck operates outdoors

Do not allow anyone to hold loads.

Do not use damaged pallets! Make sure pallets and skids are sturdy and in safe operating condition.

Do not abuse the forks! Fork misuse could cause accidents, serious injuries, damage to the truck and damage to the load.

Do not park on a grade.

Do not park in a location where traffic or operations might be obstructed.

Park a disabled truck safely in a safe, non-operating area.

Remove the key and attach "DO NOT OPERATE" or similar warning to the truck.

When you leave or park the truck:

- Push the parking brake switch to apply
- Place the direction lever in the NEUTRAL position
- Lower the forks fully to the floor
- Raise the tiller arm to vertical position
- Turn the key switch to the off position

1.7 Location of decals and machine plate

The decals and machine plates are located in the following positions:

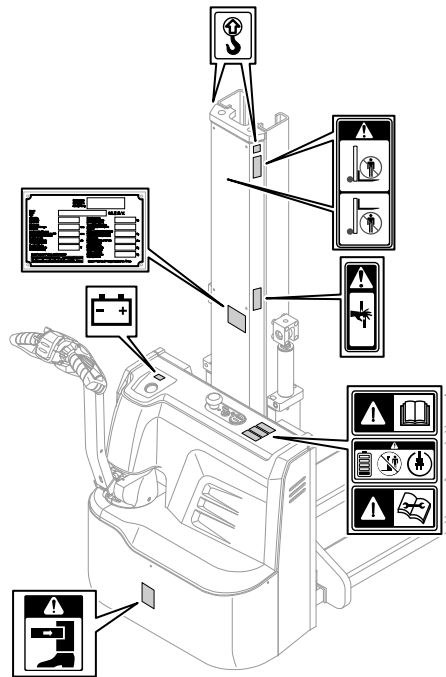

Fig. 1. Decal and machine plate positioning

1.8 Climate conditions

Normal operating conditions

The normal operating temperature for which the truck is intended is within the range of +1° C to +25° C in humidity up to 95% , provided non-condensing conditions. If temperatures exceeding +25° C are combined with long term heavy duty operation, overheating tendencies may gradually increase up to the maximum ambient temperature of +40° C . If the truck is used below +1° C, condensation, ice and thawing risks may consequently increase. If condensation occurs, the truck must be allowed to fully dry. If condensation is avoided, -10° C is permissible. A truck kept at working temperature can be used short term down to -25° C. Special equipment is required if the truck is used continuously in environment with extreme temperature or condensing air conditions.

If the truck is specified for use in refrigerated rooms, without shutting off, it can be used at temperatures down to -30° C, but it may not be left unused in temperatures below zero. Charging or long-term parking must be at temperatures of a minimum of +1° C.



NOTE

The operation and characteristics of the truck can be negatively affected by starting in temperatures below zero. Bear in mind that the truck may still be frozen, even if the ambient temperature has risen above zero.

Exceptional operating conditions

When the operating conditions differ from normal conditions , the following steps must be taken:

- If the working conditions are of a permanent nature, an agreement must be drawn up with the supervisory authority and any other party concerned.
- If the working conditions are of a temporary nature, take suitable measures such as using a larger truck or reducing the load correspondingly.

Working in hazardous environments

A truck operating in an area where there is a risk of fire, explosion, or in any other high risk area, must be specially equipped for the purpose.

**WARNING**

A truck is not normally equipped for these situations.

1.9 Emergency procedures

If the truck falls over, hold on to the steering device and warn others. Be careful of spilling battery acid and hydraulic oil.

If the machine malfunctions, stop the truck and turn the power switch to the OFF position. The truck must not be used again until an authorized technician has restored the truck to working order.

In case of a fire, press the emergency stop button, disconnect the charging plug and warn others. Know the location of all emergency devices (such as fire extinguisher, first aid kit, etc.) and how to use them. Know where to get prompt assistance.

1.10 Handling loads safely

Handle only stable loads to prevent the load from falling!

Handle only loads within the capacity of the truck as shown on the capacity plate.

Do not pick up an off-center load. Make sure the weight of the load is centered between the forks.

Under all travel conditions, operate the truck at a speed that will permit it to be brought to a stop in a safe manner.

Look around to make sure your drive area is clear. If the load blocks your view, or when you travel down a grade with the load, drive in reverse. Always look in the direction of travel.

1.11 Repairs and structural modifications

Do not modify the truck without the express permission of the manufacturer.

Do not add or remove, drill, weld or bend any parts, as the modification can affect the operation of the truck and weaken its construction.

2 VEHICLE DESCRIPTION

2.1 Overview 9

2.2 Machine plate 9

2.3 Load diagram 10

2.1 Overview

This stacker truck is a seven-wheel pedestrian operated electric stacker truck with a battery for power supply, with a built-in charger, equipped with a multi-functional tiller arm control for driving, steering and load handling. It is designed to transport pallets and pick goods on level surfaces. The maximum load and lifting capacity is 1000 kilograms.

This stacker truck is a seven-wheel pedestrian operated electric stacker truck with a battery for power supply, with a built-in charger, equipped with a multi-functional tiller arm control for driving, steering and load handling. It is designed to transport pallets and pick goods on level surfaces. The maximum load and lifting capacity is 1200 kilograms.

2.2 Machine plate

1	Designation Désignation Bezeichnung		
2	Model Type		MLE B.V.
3	Serial No. N° de série Serien-Nr.		Rated capacity Capacité nominale Nenntragfähigkeit
4	Lift Height Hauteur de levage Hubhöhe	mm	Year of manufacture Année de construction Baujahr
5	Load centre distance Distance du centre de gravité Lastschwerpunktstand	mm	Empty weight without battery Poids à vide sans batterie Leergewicht ohne batterie
6	Rated capacity Capacité nominale Nenntragfähigkeit	Ah	Drive power Puissance d'entraînement Antriebsleistung
7	Battery voltage Tension de batterie Batteriespannung	V	Battery weight Poids de batterie Batteriegewicht
	Manufacturer/Fabricant/Hersteller		Service Weight Poids de Service Eigengewicht
	Ningbo Ruyi Joint Stock Co., Ltd. ADD:656 North Taoyuan Road, Ninghai,Zhejiang 315600, China		Made / Fabriqué / Hergestellt in/ en China

Fig. 2. Machine plate

The truck's machine plate is marked with:

1. Model
2. Type
3. Serial Number
4. Lift Height (mm)
5. Load Center (mm)
6. Battery Capacity (Ah)
7. Battery Voltage (V)
8. Rated Capacity (kg)
9. Year of Manufacture
10. Weight Without Battery (kg)
11. Drive Power (kw)
12. Allowed Battery Weight (kg)
13. Service Weight (kg)

2.3 Load diagram

The load diagram shows the maximum allowed load for a specific mast height. Do not load/lift over the maximum allowed weight.

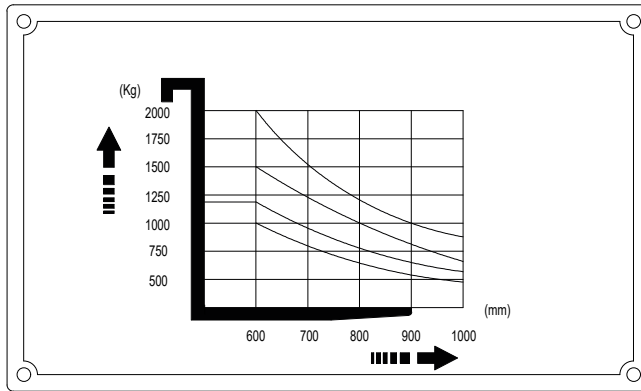

Fig. 3. Load plate

3	VEHICLE OPERATION	
3.1	Vehicle Operation	12
3.2	Daily checks before operation	12
3.3	Starting the truck	12
3.4	Tiller head	13
3.5	Fork lifting	13
3.6	Fork lowering.....	14
3.7	Driving forwards and backwards	14
3.8	Accelerating and braking.....	14
3.9	Emergency reversing.....	15
3.10	Slow speed travelling.....	15
3.11	Parking.....	15
3.12	Use, Maintenance and Charging of Storage Battery	15
3.13	Lithium-ion battery.....	16
3.14	Charger	20

3.1 Vehicle Operation

Be sure to perform the daily pre-start inspection. Where trucks are used on a round-the-clock basis, they must be inspected prior to each shift.

3.2 Daily checks before operation

- Check that there are no oil leaks.
- Check all wheels for damage or wear.
- Check if the battery is fully charged.
- Switch on the power and test the operation of the lifting hydraulics by raising and lowering the forks.
- Check the operation of the accelerator and steering by driving slowly forward and backward.
- Also check the operation of the other electrical functions.
- Check the operation of the horn.
- Check that the emergency stop operates properly.
- Always return the tiller arm to the up position.
- Check that the brake functions properly.

3.3 Starting the truck

To connect the power supply, pull up the Emergency Stop button (A) on the electrical panel.

To turn the truck ON, turn the key (B) clockwise. The battery load indicator will light up and the truck is now ready for use and all electric controls are active.

Should the charging indicator light (C) turn on, take the truck to the designated charging station and charge the battery.

Should a fault occur, the fault indicator light (D) will turn on. In this event, contact your supervisor and/or an official service technician.

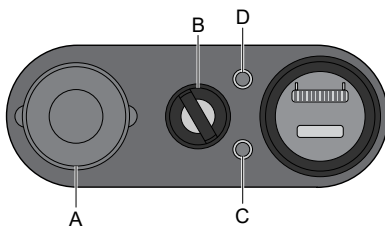

Fig. 4. Electrical panel

A	Emergency Stop button
B	Key switch
C	Charging indicator light
D	Fault indicator light



WARNING

Ensure the battery capacity is at a sufficient level for operation.

3.4 Tiller head

The tiller head is equipped with buttons for driving, lifting, braking and sounding the horn:

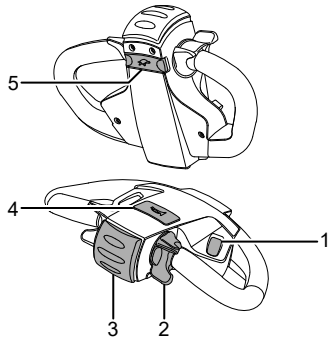

Fig. 5. Tiller head controls

1. Lifting/Lower
2. Accelerator forwards/backwards
3. Emergency reverse
4. Horn
5. Slow speed "turtle"

3.5 Fork lifting

Activate the tiller head by lowering it into the working position (B).

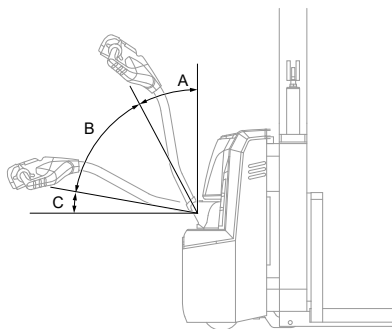

Fig. 6. Operating zone.

Press the lift/lower button to lift the forks. When the lift button is released, lifting of the forks stops.

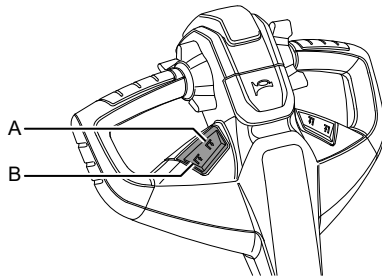

Fig. 7. Lift/Lower

A	Lift
B	Lower

3.6 Fork lowering

Press the lift/lower button forward to the arrow down symbol to lower the forks. When the descending button is released, descending of the forks stops.

3.7 Driving forwards and backwards

Always keep two hands on the tiller arm!

Rotate the accelerate knob in the desired direction. Rotate forward to move the truck forward. Rotate backward to move the truck backward. Travelling speed is controlled by the rotation angle of the accelerate knob.

The accelerate knob will move back to the start position when released. At the same time, the truck will reduce speed until it stops.

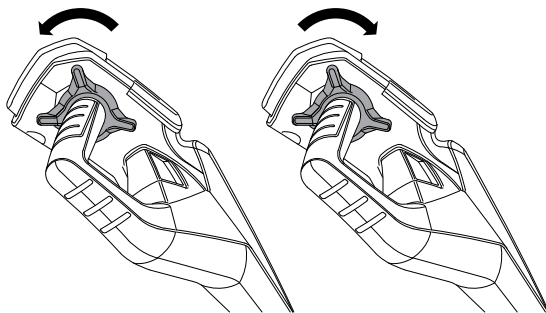

Fig. 8. Driving forwards and backwards

3.8 Accelerating and braking

By rotating the accelerator button speed can be increased or lowered.

To stop the truck, release the accelerator button.

For reverse braking, quickly change direction of the accelerator panel and release.

3.9 Emergency reversing

The red button at the end of the tiller arm is the emergency reversing button. It is a safety button to protect the truck operator from injury when the truck meets an obstacle. The truck will stop immediately and move away from the operator for a short distance if the operator touches the emergency reversing button.

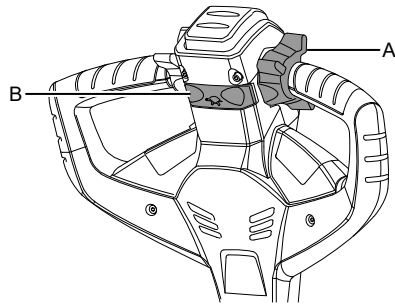

Fig. 9. Emergency reversing

A	Accelerator
B	Slow speed button

3.10 Slow speed travelling

To travel with reduced speed, press the slow speed button (with the turtle symbol) and the accelerator keys at the same time. Releasing the slow speed button will allow operating at normal speed.

3.11 Parking

To stop running release the accelerator button. The truck will now slow down until it stops. Lower the fork to the lowest position. Raise the tiller arm to vertical position. Turn the power key to the off position.

Avoid parking outside in the elements to keep the electrical parts from being damaged. Make sure the ground is dry and travel after the rain stops. Do not park the truck in a damp or wet environment unless it is properly covered.

If leaving the truck for a long period of time, disconnect the battery plug.

3.12 Use, Maintenance and Charging of Storage Battery

Only authorized personnel may recharge and replace batteries. Individuals maintaining batteries must wear sufficient protective clothing and eye wear. Charging must be performed in a flat and well-ventilated area. The charging area must be adequately spaced from materials that can constitute a hazard such as inflammable or explosive materials.

Keep the battery dry and clean. Dust can lead to self-discharge of the battery. Read and obey the safety instructions of the battery manufacturer.

Do not open or alter the battery or the charger by yourself. Only skilled and authorized persons should work with the battery and the charger. Always use protective eye wear and clothing when you work with batteries. Make sure that the surface resistance of your protective clothes,

booths and gloves is $\leq 100 \text{ M}\Omega$ to prevent build-up of static electricity. Comply with local regulations and safety instructions when changing or charging batteries. When you install a battery use the correct tools to move, connect and attach the battery correctly.

Do not keep tools or other metal objects on top of uncovered batteries. ONLY use insulated tools according to IC 60900.

Batteries should be stored in a clean, dry and well ventilated warehouse. The temperature should be between +5 and +40 degrees Celsius (+41 and +104 degrees Fahrenheit).

Check that all the cables/plugs are free from damage before charging. Check that all cables are correctly connected before switching on and using the charger. Connecting and disconnecting the battery power plug must ONLY be performed when the key switch is in the OFF position.

Battery voltage is 24V with a rated capacity of 50Ah. Charger voltage is 24V with a rated capacity of 30Ah. Green and red lights indicate the remaining battery load percentage on the battery load indicator. When fully charged, all five bars are green. With decreasing remaining capacity less bars will be green. If the remaining capacity reaches 30% a single green bar flickers.

As soon as the remaining load drops below 20%, a red bar shows. Charge at once to avoid damage to the battery. If the battery is completely discharged a full charging cycle must be performed.

ONLY use fully charged batteries. Charge the battery after each discharge. Using an insufficiently charged battery may lead to a reduced battery life.

The battery meter shows remaining charge and LCD hour meter. When the battery is fully charged all bars are lit. When only the two left bars are flashing the remaining battery capacity is <20%. At this point, lift lockout occurs. Immediately charge the battery.

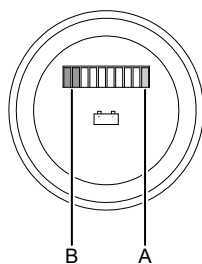

Fig. 10. Battery display indicator

A	Battery full
B	Battery low — charge immediately!

3.13 Lithium-ion battery

Requirements on Operators

1. Relevant people who are able to use, maintain and take any actions to Li-ion batteries on all electric storage and logistic trucks (hereinafter referred to as operators).
2. Only professionally trained persons, acquiring certain knowledge of Li-ion batteries, and obtaining certifications from relevant departments may maintain the battery.

Lithium-ion Battery Safety Regulation

- These signs shown below might be found either on the Li-ion battery cases or on the trucks, which are set on the consideration of the safeties of the batteries as well as the operators. All the operations must be under the guidance of them.

High Voltage Warning :

It indicates a possible danger of electric shock. All the electric work of the equipment must be finished only by qualified professional workers. Unauthorized disassembly is prohibited

Corrosive Risk Sign :

It indicates to pay attention to protect the products when unsafe factors exist over the production.

Waterproof & Humidity proof Sign :

It indicates to protect the products from rain, water and humidity.

No Fire Sign :

It indicates that fire is prohibited in this area when the product is on.

Do Not Step Sign :

It indicates the products must not be stepped on.

- The use of Li-ion battery trucks shall be in accordance with the requirements of temperature, humidity and environment specified in the truck instructions, and the maintenance and disassembly of lithium battery shall be carried out when the battery case is clear without

any foreign bodies, especially metal tools, and there are no impurities or blockages in the air duct.

- Operators are forbidden to short-circuit connect lithium batteries, otherwise the system will be seriously damaged and people will be injured.
- Li-ion batteries should be kept away from heat, fire and avoid long time direct sunlight. Li-ion batteries must not be placed in liquid (such as water, solvent) or high humid environment to avoid damages caused by leakage or short circuit.
- Installation, commissioning and maintenance of lithium batteries in rain and snow weather should be carried out indoors to prevent short circuit caused by rainwater entering Li-ion battery system.
- Because of the communication protocol between the management of lithium batteries and trucks, it is prohibited to interchange lithium batteries with the same voltage and capacity on different trucks without the permission of the host plant.
- It is forbidden to mix Li-ion batteries with other batteries in one truck. For the truck that is about to replace batteries, it is necessary to check up whether the new batteries are with the same model and with the same group or not before restart it.
- The Li-ion battery cases shall be transported and moved strictly in accordance with the regulations without any improper operations like towing, prying and kicking, which will cause mechanical impact on the batteries, such as dropping, impacting and pressing. It's highly prohibited to overlap, upside down and side-up lithium battery cases.
- It is necessary to ensure the correct connection and normal operation of the lithium battery management system whether charging or discharging, and to ensure the normal communication between the lithium battery management system and the truck system.
- Li-ion batteries are prohibited to contact and to be placed together with objects that will possibly cause a short circuit. Sharp stuff and workers in clothes and accessories with metal are not permitted to get close to Li-ion batteries.
- Periodically check the lithium battery information displayed by truck meters. If there is any problem, do not open and operate the battery case by yourself. Contact relevant technical personnel immediately for further guidance.
- Unauthorized disassembly, damage and installation of lithium battery components are strictly prohibited. It is forbidden to dissect lithium batteries or lithium battery groups without authorization in order to avoid danger. Non-professional workers are forbidden to replace the data transmission interface and voltage acquisition interface of lithium battery management system to prevent short-circuit damages to system components and even cause fire. Safety warning signs must be obeyed for safety's sake.
- If operators find any of the following situations or have any concerns about the safety of the product, shut down the truck first, and take measures like disconnecting the power connection to ensure the safety of both the operators and the truck, then immediately contact the relevant personnel for further guidance. Solutions provided as follow:
 1. Contact relevant technicians for emergency repair when see the signs of overheating, smoking, sparking; battery pack damage (such as rupture), battery leakage; battery system case and power cord take in water.
 2. Contact relevant technicians for an overhaul when see ruptures or damages of the power cord, plug, extension cord, protective device; or when confronted with the problems that don't threat personal or truck's safety, like the truck fails to work normally.

Power display while logged on

- Green light constantly ON: 78% — 100%
- Blue light constantly ON: 52% — 77%
- Yellow light constantly ON: 26% — 76%
- Red light constantly ON: 16% — 25%
- Red light flashing: < 15%

**WARNING**

When the red light is always on, please prepare to drive the truck to the charging place for charging; The red light flashes as a warning, indicating that the truck is about to stop working. Please charge the battery immediately. If it is used continuously, the battery life will be seriously damaged.

Power display while logged off

- Green light constantly ON: > 50%
- Yellow light constantly ON: 20% — 49%
- Red light constantly ON: < 20%

Requirements on Charging the Li-ion batteries

- The charging temperature range is 0-50°C. Li-ion batteries are not allowed to charge in the environment below 0°C except those with heating system. Low-temperature charging will cause lithium evolution and affect the service life of Li-ion batteries.
- The charging place should keep clean and well ventilated, and always keep away from inflammable and explosive articles. Fireworks are strictly prohibited in the charging area.
- Operators are suggested to help themselves to charge only with the certain charging equipment coming with the truck from the manufacture to maximize the safety performance of Li-ion batteries. Make sure to connect the positive and negative poles correctly and never do reverse charging.
- After the battery is fully charged, unplug the charging line in time to avoid other safety problems.
- Abnormal termination of charging may occur during the charging process of lithium batteries. For example, if the charging voltage is too high or the charging current is too large. The phenomenon is defined as "Abnormal Termination of Charging". When it occurs, it may indicate the leakage of lithium batteries or failure of some parts. It is necessary to notify relevant technicians for a complete inspection, finding out the causes and solving them before resuming the charge.

Requirements on discharging the Li-ion batteries

- Discharge temperature range is -20-60°C.
- When a lithium battery fault is found in display during the start-up or operation of a truck, the cause of the fault should be inquired according to the display code and the schedule of the truck instruction, and the technical personnel should be notified to deal with it in time.
- It is necessary to ensure that lithium batteries are not less than 50% charged before maintenance or repair.
- To prevent damages of lithium batteries caused by over discharge, it is necessary to charge lithium batteries in time when the instrument displays low charge alarm.

Requirement on transportation and unloading

- Strong and sturdy packaging is highly recommended when Li-ion batteries are in transit..
- Sign of water proof, sign of humidity, sign of upward, sign of careful and light handling shall be attached to the out packages. In case of being damaged, the battery cases must be placed upward according to the sign.
- When the lithium batteries are dislocated or extruded during transportation, the exposed wiring harness and connectors should be checked to see if the lithium batteries are damaged or deformed. In case of smoke, sparking, stay away from the scene immediately, and professional technicians should be notified.

Requirements on storage

- The storage of lithium batteries should be in clean and ventilated rooms with ambient temperature ranging from - 10 ~35 °C (recommended storage temperature ranging from 0

~25°C). Long-term storage batteries (more than 3 months) should be placed in an environment with temperature of 25 ± 3 °C) and relative humidity of 65 ($\pm 20\%$).

- The contact between lithium battery and corrosive chemicals or gases shall be avoided, so as to prevent the corrosion of lithium battery or its connecting parts, affecting the appearance and service life of the battery.
- Keep Lithium batteries away from fire and heat, meanwhile, keep the batteries dry.
- Insulation, waterproof and dustproof are required over the storage. Make sure that the protective cover plate above the lithium battery case is fixed tightly without defects and damages. The battery case should be covered with insulation materials and sealed if there is no sealing cover plate.
- When lithium batteries are to be stored, the charge should be above 30%. In order to prevent over discharge during long-term storage (more than 3 months), batteries should be charged regularly, keeping the charge at 50%-80%.
- It is required to conduct a charge check once a month for those long-term parking trucks. After check, make sure the charge is between 50% and 80%. Charge it till the required amount if the charge is insufficient.
- Long-term idle lithium batteries need periodic charge-discharge activation and a standard charge-discharge cycle once a month.

3.14 Charger

The standard configuration for this truck is with a built-in charger.

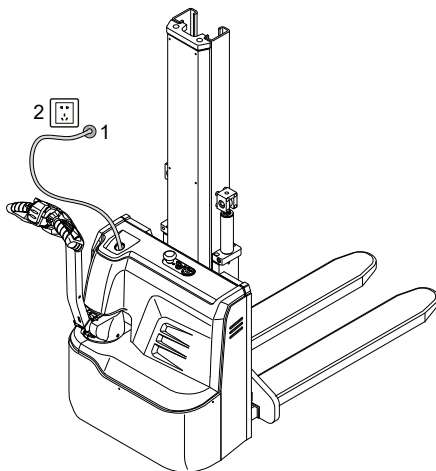

Fig. 11. External battery charging

- Connect the plug (Pos. 1) to the main supply (Pos. 2)

Charging stations must comply with all standards, legislation and regulations which may vary from region to region. Charging stations should be signposted and have proper ventilation. Hydrogen gas forms during charging. Make sure the charging area is well ventilated. Do not smoke or bring open fire or sparks near the charging area to avoid the risk of explosion and fire. Safety equipment such as an eye douche, washing facility, fire extinguishers and protective glasses should be available.

The battery charger must be kept dry and free of dust. Check the vents regularly and make sure the vents are not blocked. Use only in a dry, dust-free and well-ventilated space. Keep charger away from combustible, corrosive or explosive substances. Clean with a dry cloth only. Switch power off and disconnect power plugs before cleaning the charger. Handle the battery cable with care. Careless handling can damage the cable and cause a serious safety risk.

Only use charger with the factory delivered batteries. Make sure battery and charger match. Use the correct charging voltage / output. Do not use a damaged or faulty charger. DO NOT use a damaged or faulty battery. Do not connect the charger to an ungrounded outlet.

Disconnect the battery power plug from the truck's power plug (#1), connect battery to the charger (#2). Then connect charger to the AC wall plug (#3) and switch on charger (#4).

After connecting the power plug to a power source, charging commences. During charging indicator lights on the charger flashes, depending on the chosen program. Once the battery is fully charged the 100% indicator light flashes.

The charger front panel has the following controls and indicators:

- Power switch
- Info. key
- Status indicator lamps
- Information window
- Information content window

The charger has the following Indicator lights:

- On
- 80%
- 100%
- Equalizing charging
- Initial charging

**NOTE**

Do not dispose of the battery system with household or industrial waste. Always return the battery system to the manufacturer or a certified recycling company for recycling. Acid and electrolyte are chemical waste and should be treated as such according to local regulations.

4	MAINTENANCE	
4.1	Maintenance.....	23
4.2	Levels of maintenance.....	23
4.3	Routine maintenance.....	23
4.4	Level 1 maintenance.....	23
4.5	Level 2 maintenance.....	24
4.6	Instructions for ordering parts.....	24
4.7	Common failures and troubleshooting	24
4.8	Noise level	26
4.9	Hand-arm vibration.....	26
4.10	Solid particle and liquid ingress protection	26
4.11	Transportation of truck.....	26
4.12	Loading, unloading, transportation and storage of truck	27
4.13	Storing the truck.....	27
4.14	Long term storage	27
4.15	Hydraulic oil.....	28
4.16	Proper disposal of a decommissioned truck.....	28
4.17	Lifting the truck.....	28

4.1 Maintenance

Taking proper care of your truck is a vital part of the overall planned maintenance program and will help to ensure a long and safe operational lifecycle.

Be sure to perform regular inspections. If you fail to perform required inspections, it could lead to damage and accidents.

Operate the truck at a reduced speed when performing an operational inspection. If operated at higher speeds during an operational inspection, it could cause an accident if the truck is faulty.

Follow these rules to help avoid injury and to service your truck properly:

- Make sure the service area is safe.
- Park the truck on level ground with the forks lowered until the fork tips touch the floor.
- All motors stopped and power switched off.
- The wheels blocked.

All repairs must be made by authorized personnel. Follow the recommended safety procedures. Use only the right tools for the job. Do not bypass any electrical switches on this truck.

If during operation the truck becomes unsafe in any way, the matter must be reported immediately to the user's designated authority, and the truck must not be operated until it has been restored to a safe operating condition.

Moisture is harmful to the electric components of the truck. When washing, Do not splash water or steam on the components under the cover.

This truck consists of precise components. Do not attempt to make adjustments or repairs by yourself. Consult your authorized dealer.

Inspections of the truck should be performed frequently. To ensure safety Do not operate a damaged or defective truck.

4.2 Levels of maintenance

Three levels of maintenance are required:

- Routine maintenance
- Level 1 maintenance
- Level 2 maintenance

4.3 Routine maintenance

Daily inspection. Examine whether the power supply cable is undamaged. Check for any visible damage. If any abnormality is observed, please conduct repairs as soon as possible.

4.4 Level 1 maintenance

Once every week. In addition to the routine maintenance, check for loose components, oil leakage, damaged or missing power cable, overheating, damaged indicator lights. Check if the truck is clean. If any abnormality is observed, please conduct repairs as soon as possible.

4.5 Level 2 maintenance

Should be performed periodically and overall inspection should be performed according to following requirements:

1. Mechanical system maintenance must be performed every 6 months. Check and if necessary replace the lubricating oil for the transmission gear and bearing. Apply lubricant to the rotating joints. Check for any loose components. Check if the wheels are rotating easily and if the fork rises and descends normally. The operation noise of the Powered Pallet Truck should be no greater than 70db after maintenance.
2. Hydraulic system maintenance must be performed every 12 months. Check if the oil cylinders are in a good condition and/or whether there is any internal or external leakage. The hydraulic oil should be clean and must be changed every 12 months.
3. Electric equipment maintenance must be performed every 3 months. Check whether the electric connectors, switches and insulations are clean and working reliably. The insulation resistance of the electric equipment and of the Powered Pallet Truck body should be greater than 0.5MΩ.

If any abnormality is observed, please conduct repairs as soon as possible.

4.6 Instructions for ordering parts

When ordering parts, or when contacting your authorized dealer to have your truck repaired, be sure to provide the following information:

- Model
- Serial number of the truck
- Order number of the part
- Name of the part
- Number of parts ordered

The truck's type and serial number are listed on the front page of the manual or on the identification plate on the truck. The order number and the name of the parts are listed in the spare parts pages of the manual supplied with the truck or can be obtained from your authorized dealer.



NOTE

Use only original spare parts.

4.7 Common failures and troubleshooting

Fault	Cause	Solution
Stacker cannot start (contactor does not works)	Fuse of control circuit burnt	Replace
	Bad contact performance or damage of power switch	Repair or replace
	Fuse of main circuit burnt	Replace
	Bad contact performance or damage of key switch	Repair or replace
	Battery connection loosened or fallen	Fasten

Stacker cannot start (contactor works)	Brake of driving wheel not closed, truck in braked condition	Repair or replace
	Carbon brush of drive motor worn or bad contact between commutator and carbon brush	Repair or replace
	Coil of drive motor disconnected bad contact	Repair or replace
	Bad contact performance of contactor	Repair or replace
	MOSFET circuit plate faulted	Repair or replace
Stacker can only travel forward (or backward)	Contactors have poor contact performance or burnt	Repair or replace
	Circuit panel faulted	Repair or replace
Stacker cannot stop during travelling	Contacts damaged	Cut off power supply in emergency and replace contacts
Braking failure	Mounting screw of micro switch loosened or damaged	Adjust or fasten screws, or replace micro switch
	Connecting wire of brake loose or brake damaged	Fasten screws or repair brake
	Braking plate worn	Replace braking plate
Steering stuck	Steering gear bearing damaged	Replace bearing
	Steering gear bearing lacks oil or has too much dust	Clean bearing
Drive wheel has heavy and noisy steering, motor in overload condition	Gear and bearing have foreign matters	Clean or replace bearing
	Bearing mounting has gaps	Adjust gap
	Load wheel bearing damaged	Replace bearing
Forks do not lift	Overloading	Reduce load
	Pressure of relief valve too low	Adjust it higher
	Lift cylinder has abnormal inner leakage	Replace sealing parts
	Inadequate hydraulic oil	Add some filtered hydraulic oil
	Inadequate battery voltage	Charge battery
	Tiller head not in horizontal or vertical position, hydraulic pump motor not powered on	Improper operations
	Hydraulic pump motor damaged	Repair or replace
	Hydraulic pump damaged	Repair or replace
	Lift button switch damaged	Repair or replace
	Key not turned on or damaged	Repair or replace
Battery voltage severely inadequate	Charge	
Forks do not descend after lifted	Inner mast distorted due to overloading	Repair or replace
	Outer mast distorted due to overloading	Repair or replace

	Rollers in mast stuck	Repair or adjust
	Guide rod of mast crooked	Repair or adjust
	Return oil hole block	Clean
	Solenoid valve of hydraulic pump out of control	Exclude fault of solenoid valve
Terminal voltage of storage battery lowered (after charging)	Some single cell damaged	Repair or replace
	Battery liquid level low	Add electrolyte
	Impurities in electrolyte	Replace electrolyte
Chassis swings during travelling	Nuts for fixing driving wheel become loose or fallen	Fasten locknut
	Balance wheel, drive wheel and two front wheels are not in the same plane	Adjust screws on the balance wheel to make the four wheels within the same plain

4.8 Noise level

Noise level at operator's ear (according to EN 12053) = 70dB(A).

4.9 Hand-arm vibration

Hand-arm vibration level (according to EN13059) = < 2,5 m/s².

4.10 Solid particle and liquid ingress protection

The truck is protected against solid particle and liquid ingress at level IP44 (motor), IP53 (controller) and IP54 (hydraulic station) according to the International Protection Marking standard (IEC60529).

4.11 Transportation of truck

If the truck is to be transported on trailer or a rail car, support the end of the truck facing the operator with wood beams. Fix the front wheels with blocks. Tie the truck firmly with suitable ropes.

Be sure to take the following safety precautions before loading and shipping forklift trucks:

- Always block the trailer or rail car wheels before loading the forklift truck.
- Position the forklift truck on the trailer bed or rail car.
- Apply the service brake and then apply the parking brake. Place the direction lever in the NEUTRAL position.
- Turn the key switch to the OFF position and remove the key.
- Block the wheels and secure the forklift truck with suitable tie downs.
- Do not turn the steering wheel after the forklift truck has been secured. It may loosen the tie-downs.

4.12 Loading, unloading, transportation and storage of truck

1. Storage of truck

If the truck will not be used for over 2 months, it should be parked in a well-ventilated, frost free, clean and dry room, and the following measures should be taken:

- Clean the truck thoroughly.
- Lift and lower the forks completely for several times, and check if it's normal.
- Lower the forks to the lowest position.
- Block up the drive wheel so that it is free from the ground.
- Apply a layer of thin oil or grease to all the exposed surfaces of mechanical parts.
- Lubricate the truck.
- Inspect the battery conditions and the electrolyte, and apply non-acid lubricating grease to the battery terminals.
- Spray all the electrical contacts with proper spray.

2. Transportation of truck

If the truck is to be transported for a long distance, block up the drive wheel so that it is free from the ground, and fix the two load wheels with wedge blocks. Bind the truck and the transportation truck firmly with straps.

3. Loading and unloading the truck

Before loading and unloading, please first check the overall truck weight marked on the machine plate, and choose proper hoisting and loading/unloading devices. When hoisting, the truck should be kept horizontal, and lowered to the ground slowly. People around should be careful, and it should be guided by a person. If making loading/unloading with a truck, first observe the condition of the bottom of the truck being loaded/unloaded. Operate cautiously when the forks are inserted to the bottom of the truck to prevent damaging the drive wheels, caster wheels and load wheels of the truck.

4.13 Storing the truck

To ensure the long life of your truck, be sure to take the following steps at the end of each shift:

- Park the truck in an authorized area.
- Block the wheels securely.
- Check for oil or other fluid leaks.
- Clean the truck to keep it free of dirt and oil. This will make it easier to spot loose or defective parts.

4.14 Long term storage

If your truck is stored for any length of time, take the following safety precautions to reduce the risk of deterioration of the truck components:

- Always lower the forks to base position to minimize rod exposure.
- Fully charge the battery and then recharge it for equalizing if the truck is left standing for more than three days. Charge the battery for equalizing at least once a month if the truck is to be left standing for more than a month.
- Disconnect the battery plug/connector after charging.

If the truck is not used for a longer period of time, store it in a cool (above 0 degree Celsius) and dry place on an even surface. Before storage, charge the battery, and recharge it every 2 or 3 months to prevent damage during storage. It is advised to remove the battery from the truck and to use a charger with a charging algorithm to ensure the longevity of the battery.

If the truck returns to use after it has been stored for several months, it must undergo maintenance as instructed in this manual. Otherwise, normal daily checks are sufficient.

If it is necessary to store the truck outdoors, park it on a hard level ground, secure with wooden blocks and cover it with a waterproof plastic sheet to protect it from moisture or dust.

Moisture is harmful to the controller. Do not splash water or steam clean the controller or other electric parts when cleaning the truck.

More precautions may have to be taken according to the place of storage, storage period and season. When you store your truck, consult your authorized dealer.

4.15 Hydraulic oil

The recommended hydraulic oil is L-HV32, with an environment temperature between -5 and +40 degrees Celsius (+23 to +104 degrees Fahrenheit).

4.16 Proper disposal of a decommissioned truck

Consult your authorized dealer for how and where to dispose of a decommissioned truck. Improper disposal of a decommissioned truck and other waste such as tires, batteries, coolants and hydraulic oils can be harmful to the environment. All waste must be treated and disposed of according to local laws and regulations in the country of use. The truck itself is not hazardous waste and can be recycled.

4.17 Lifting the truck

To lift the truck, please use the lifting points as shown

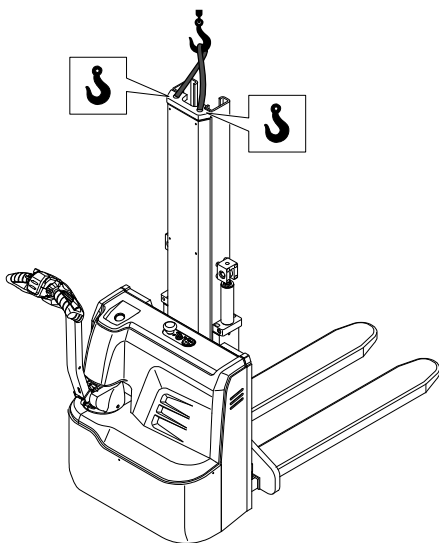

Fig. 12. Lifting points

5 SPECIFICATIONS

5.1 Truck data 30

5.1 Truck data

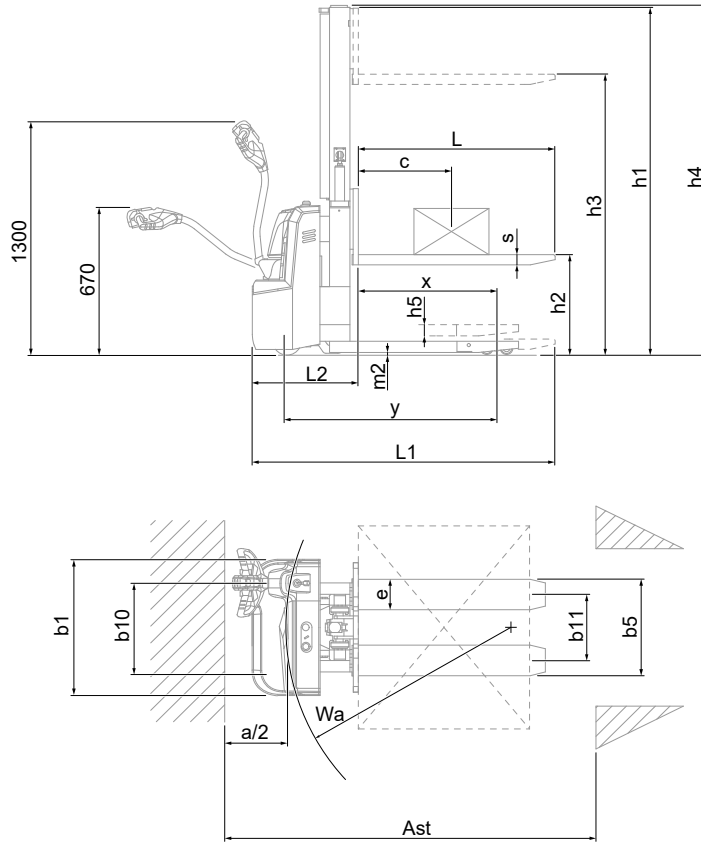

Fig. 13. Dimensions

Characteristics	1.2	Manufacturer's model designation		SPB12QLMI
	1.3	Driving mode		Electric (Lithium battery)
	1.4	Operator type		Standing/ Pedestrian
	1.5	Load capacity	Q (Kg)	1200
	1.6	Load center distance	C (mm)	600
	1.8	Front overhang	x (mm)	812
	1.9	Tread	Y (mm)	1272
Weight	2.1	Service weight (with battery)	(Kg)	685
	2.2	Axle load, front/rear, laden	(Kg)	1190/695
	2.3	Axle load, front/rear, unladen	(Kg)	194/491
Wheel chassis	3.1	Wheel (rubber, high elasticity, pneumatic, PU)		PU
	3.2	Wheel dimension, front		Ø195×70

	3.3	Wheel dimension, rear		Ø80×70
	3.4	Additional wheel (dimension)		Ø150x60
	3.5	Wheel number, front/rear (x= driving wheel)		1x+1/4
	3.6	Tread, front	b10(mm)	523
	3.7	Tread, rear	b11(mm)	390
Dimensions	4.2	Height of mast in lowered position	h1(mm)	2050/2400
	4.4	Lift height	h3(mm)	1600/1950
	4.5	Max. Height of mast in working position	h4(mm)	2060/2410
	4.6	Lift height of straddle lift	h5(mm)	120
	4.15	Height, lowered	h13(mm)	90
	4.19	Overall length	l1(mm)	1690/1770
	4.20	Length to fork face	l2(mm)	619
	4.21	Truck width	b1(mm)	800
	4.22	Fork dimension	S/e/l (mm)	60/180/1070 (1150)
	4.25	Overall fork width	b5(mm)	570
	4.32	Wheelbase ground clearance	m2(mm)	17~137
	4.34.1	Aisle width for pallets 1000x1200 crossways	Ast(mm)	2286
	4.34.2	Aisle width for pallets 800x1200 lengthways	Ast(mm)	2224
	4.35	Turning radius	Wa(mm)	1450
Performance data	5.1	Travel speed, laden/unladen	Km/h	4.5/5
	5.2	Lift speed, laden/unladen	m/s	0.11/0.10
	5.3	Lowering speed, laden/unladen	m/s	0.12/0.10
	5.8	Max. incline grade, laden/unladen	%	6/15
	5.10	Travelling brake		Electromagnetic
Motor	6.1	Driving motor power	kW	0.65
	6.2	Lifting motor power	kW	2.2
	6.4	Battery voltage/rated capacity	V/Ah	24/60
	6.5	Battery weight	Kg	20
	6.6	Battery dimension (LxWxH)	mm	365x176.5x516
	10.7	Noise level at drive EN 12053	dB(A)	70

6 HYDRAULIC SCHEMATICS

6.1 Hydraulic Schematics 33

6.1 Hydraulic Schematics

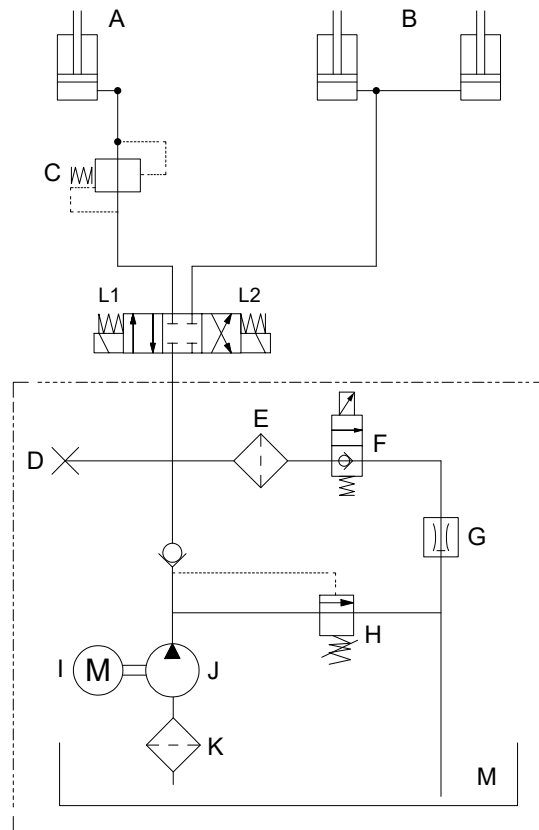

Fig. 14. Hydraulic system

A	Lift cylinder
B	Initial lift cylinder
C	Pressure relief valve
D	Plugged port
E	Filter
F	Direction control valve
G	Flow valve
H	Pressure relief valve
I	Motor
J	Oil pump
K	Filter
L	Solenoid valve
M	Oil tank

7 ELECTRIC SCHEMATICS

7.1 Electric Schematics..... 35

7.1 Electric Schematics

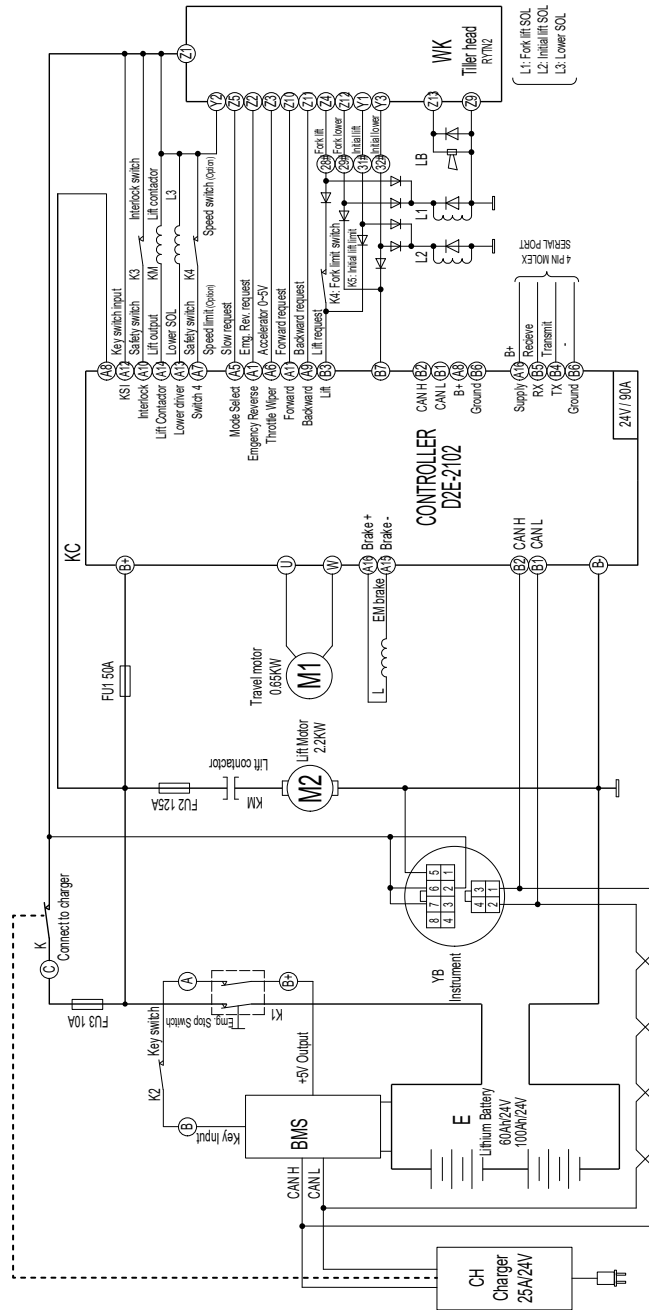

Fig. 15. Electrical system



**MLE B.V. (33274459)
Hefbrugweg 77
1332 AM Almere
The Netherlands**

© 2024. All rights reserved. All registered trademarks are the property of their respective owners. Some products may be shown with optional equipment.